Mobile Digital Video Recorder

User's manual



Copyright c 2005-2007
All Rights Reserved

TABLE OF CONTENTS

Section	Page
I. Product Components and Features	3
II. Installation Guidelines	4
II-2 Mounting / Enclosing the MDVR	4
II-3 Installation Parts and Materials Required	5
II-4 MDVR Product Views	5
II-5 MDVR Dimension	6
II-6 MDVR Package Contents	7
II-7 MDVR Installation Location Guidelines	8
II-8 MDVR Installation Instructions	9
II-9 MDVR Installation Layout	9
II-10 MDVR Bridal Connection Guideline	10
II-11 MDVR Visual Orientation	14
II-12 Handheld IR Remote Controller Functions	16
III. System Start-up/ Shut down	17
IV. MDVR system layout	18
IV-1 Advertisement	20
IV-2 Music	21
IV-3 Movie	22
IV-4 Search	23
IV-5 Event	23
V. System Setup Management	24
V-1 System Setup	25
A) Date/Time	27
B) General	28
C) Priority Record	29
D) HDD Format	30
E) Network	31
F) Server Connect	32
G) Security	34
H) Default Setup	36
I) USB Operation	38
J) Driver Info	40
K) Other Setup	41
V-2 Camera Setup	42
V-3 Recording Schedule	43
V-4 Event Setup	44
V-4-1 Sensor Menu	44
V-4-2 Motion Detect Menu	46
V-5 System Information:	48
VI. System Firmware Upgrade Procedure	48
VII. Compact Flash Card management	52
VIII. Hard Disk File Structure	53
IX. GPS Operation (Optional)	54
Appendix A	56

I. Product Components and Features

System Recording Module and Mounting Assembly

- Ultra compact case, extremely low weight, high temperature resistance, and vibration resistant
- Quick-Release removable Recording Module with tamperproof lock and secure controls
- Flexible Mounting Assembly for permanent connection to vehicle or permanent installation
- Individual wire connections for audio, video, power, inputs/outputs, and accessory assemblies
- 12v, 3Amp regulated power for use with cameras, inputs/outputs, and accessory assemblies
- Full support for NTSC or PAL video inputs and outputs, audio channels, VGA display
- Communications supported through TCP/IP network interface and USB connection to PCs
- Hand-held, IR controller with On-Screen Display (OSD) for all operations of the MDVR
- 2.5-in. mobile anti-vibration and shock resistance HDD

Video and Audio DVR Features and Capabilities

- 4 channels for video input, full-motion (30FPS/camera) continuous or priority video recording and live display
- 4 channels for high-fidelity, digitally recorded, synchronized audio matched to 8 video channels
- Continuous recording while in the playback mode
- User friendly criteria to playback the events associated video only
- Automatic timer to resume the live display if the unit is idle for user defined timings
- **MPEG-4** video compression for high quality, low storage recording and playback
- User-selectable settings for quality and audio record enable/disable for each video channel
- 12v power supply for multiple devices such as cameras, sensors, relays and any other accessories
- Selectable frame rate with event-triggered burst recording speeds up to 30FPS/camera
- Multiple alarm inputs with selectable pre-alarm and post-alarm record timings
- TV output channel for live video and recorded video viewing

Streaming Video Output for Multimedia Contents

- DVD-quality streaming audio/video with NTSC or PAL composite or VGA output
- Flash card, USB ,network media update
- Independent operation of DVR and streaming advertising simultaneously

Remote Connection Capabilities

- Handheld Infra-Red controller with OSD for quick access to recorded video and settings menus
- 2 USB connection for file transfer, PC-based file transfer and settings management
- PC-Based Client software for live viewing, playback video, playback events associated video, and downloading capabilities
- Support CMS (Central Management System), Auto download program, RMS (Remote Management System) software program, Playback Analysis Program;

Accessory Modules for MDVR

- Video Interface Module including GPS location and speed
- Vehicle Motion Manager includes 3-axis inertia sensor to determine video-matched motion events
- Video event search allows intelligent searching of recorded video based on event logs
- Control panel for operation(optional)

II. Installation Guidelines

II-1 Installation Environment Requirements

In order to ensure the reliable operation of your Mobile Digital Video Recorder (MDVR) within the terms of the product warranty, follow these instructions for installing your MDVR

- a) Follow all electrical codes, adhere to all requirements for your vehicle and for other connected equipment while installing and operating the MDR.
- b) Use only a regulated 12-volt DC or 24-volt DC (3 ~ 5 Amps) certified power supply for installation in vehicles. The MDVR can handle power ranges from 9v ~55v DC. Follow the installation and operating instructions provided to ensure a steady and reliable source of installation. Handle all electric equipment and connections properly to avoid injuries.
- c) Even though the recording unit may not be turned on, live power exists in the mounting assembly and precautions should be taken to avoid shock or short circuit. Disconnect the power supply from its source before connecting or disconnecting the MDVR mounting assembly from the power supply.
- d) Do not attach any device without specified or approved by Vendor.
- e) Attach the MDVR ground cable to the vehicle correctly to complete the power circuit.
- f) Install the MDVR in a dry location shielded from direct contact with excessive humidity and moisture, rain or other sources of liquid spills. Do not install on a recessed surface where liquids may accumulate or under surfaces where liquids may drip.
- g) Do not handle the MDVR with wet hands, while standing in water, or while in contact with other sources of water or moisture that could create a shock hazard.
- h) Install the MDVR out of direct sunlight and away from direct sources of heat.
- i) Do not mount the unit to a surface subject to excessive vibration, or must mount the vibration dampening system if necessary.

II-2 Mounting / Enclosing the MDVR

- a) MDVR may be operated in a totally sealed enclosure with no cooling airflow, ensure that the operating temperature of the MDVR does not exceed 140°F (60°C) or that the standing temperature does not exceed 175°F (80°C). The minimum operating temperature for the MDVR is -20°F (-28°C). (The below note is for reference) If the minimum temperature is expected to exceed connect an auxiliary heat source.
Note:
If without the Heater, the MDVR's working temperature is -20 °C ~ +45 °C centigrade, with the Heater, the MDVR's working temperature is -45 °C ~ +65 °C centigrade.
- b) MDVR assembly may be mounted on a flat surface, provide at least 6 inches (15cm) clearance for cooling airflow around the remaining sides to provide adequate heat dissipation.
- c) To clean any surface of the MDVR, use only cleaners approved for electronic equipment or components. Avoid chemical or household cleaners.
- d) Disconnect MDVR mounting assembly from the power supply when not in use for extended period of time.

II-3 Installation Parts and Materials Required

The following common tools and parts are required to install MDR

- Drill and bits for mounting in vehicle
- Screws/bolts and vibration dampening washers as appropriate for mounting
- Wire cutters and wire connectors
- Test for voltage and electric current

II-4 MDVR Product Views

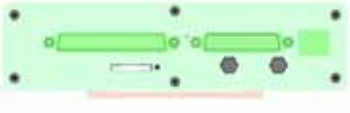
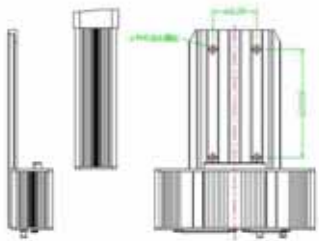
	
<p>Front View</p>	<p>Rear View (without connections)</p>
	<p>Assembled Chassis Details</p> <p>Height 4.9 cm (1.93 inch) Width 17.9 cm (7.04 inch) Depth 24.5 cm (9.64 inch) Weight 3.25 lb</p> <p>Recording Module (Removable Component)</p> <p>Height 4.6 cm (1.81 inch) Width 17.9 cm (7.04 inch) Depth 17.6 cm (6.92 inch)</p> <p>Module Removal Clearance 16.5 cm (6.49 inch) Installation Clearance (except base) 10 cm (6 in)</p>
<p>Mounting Assembly / Recording Module Removed</p>	

II-5 MDVR Dimension

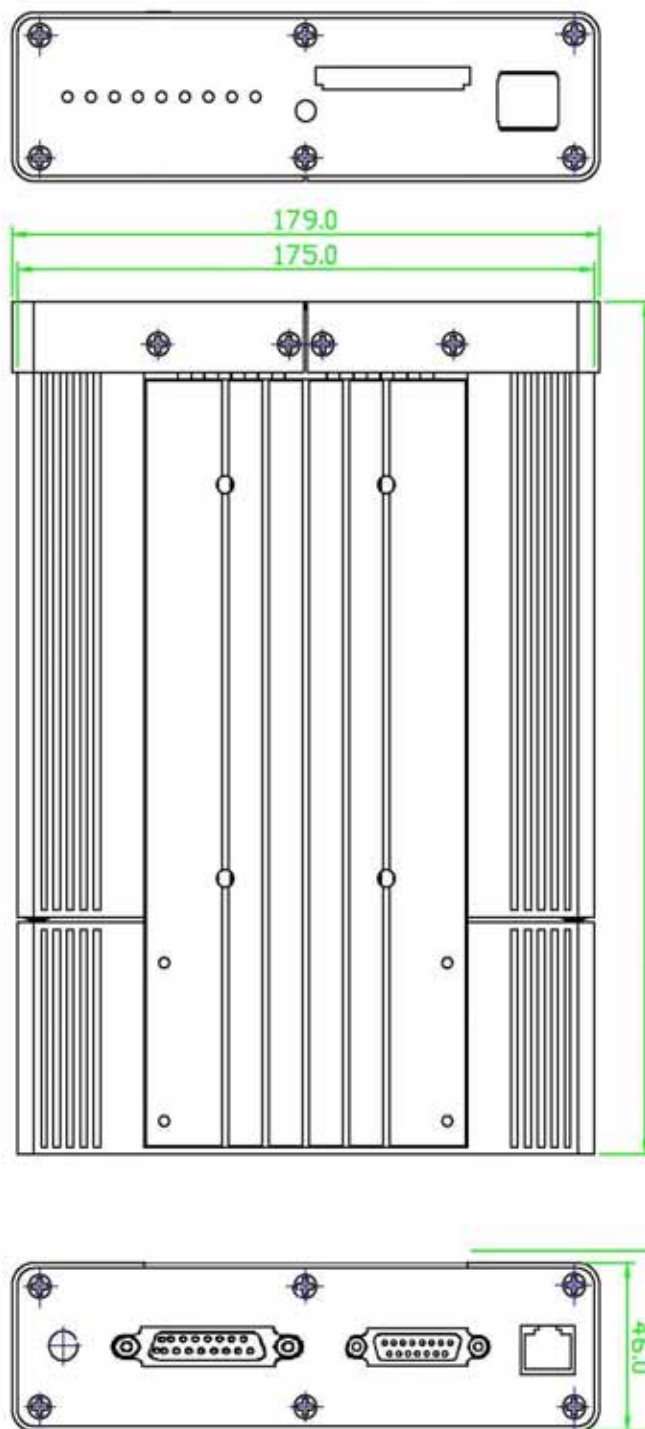

II-6 MDVR Package Contents

The following materials are shipped with the MDVR. Ensure that you unpack all contents of your shipment and confirm receipt of the following items for each unit:

- a) MDR Recording Module and Mounting Assembly
- b) DB37: AV input / Video input Cable/ Sensor connector Cable
- c) DB25:AV output / Video output Cable(VGA connector)/ Inertia Sensor connector Cable
- d) 20 PCs screws
- e) USB Cable
- f) GPS Antenna (with GPS equipped models only)
- g) POWER Cable
- h) CD: User Manual/Related introduction manual
- i) Hand held IR remote controller (batteries not included)
- j) Vibration absorber



a



b



c



d



e



f



g



h



i



j

II-7 MDVR Installation Location Guidelines

Following are the general guidelines for the installation purposes. Choose a location in the vehicle that meets the following items:

- Power:** It is recommended that the MDVR be connected to the vehicle ignition. Battery power is used only when the vehicle is running. MDVR could drain any vehicle battery over time if the ignition is not turned off.
- Connection:** Connect only to appropriate power supply and ensure proper grounding of the circuit.
- Moisture:** Protect unit and connections from environmental sources of moisture and liquid spills.
- Temp:** Do not install where unit temperature will exceed 140°F (60°C), fall below -20°F (-28°C) or store the unit where temperatures rise above 175°F (80°C). Avoid direct exposure to sunlight.
- Ventilation:** Provide sufficient ventilation with a minimum of 6 inches cooling clearance to ensure proper operating temperature for the unit.
- Vibration:** If necessary, provide additional shock mounting to prevent damage and wear by excessive vibration.
- Clearance:** Front clearance of 8 inch is required to slide the recording module from the mounting assembly.
- Wiring:** Install where mounting assembly wires have sufficient clearance and will not be crimped or subject to wire insulation damages due to vibration.
- Access:** Secure the MDR so that passengers or drivers cannot tamper or damage the unit, cameras, wires or other accessories. Do not mount where access to any other vehicle component will be restricted.
- Injury:** Install the unit, cameras, accessories and wires so that no injuries can be caused through impact with equipment during vehicle operation. Ensure that all transportation regulations are followed to avoid passenger injury should they come in contact with the installed equipment.

II-8 MDVR Installation Instructions

Follow these guidelines when installing the MDR:

- Remove all components provided in the package.
- Disconnect any power supply or device.
- Locate a proper spot to install the mounting assembly and provide any additional shock absorption if necessary.
- Locate a reliable electrical ground point in the vehicle.
- Make all connections to the rear of the mounting assembly.
- Connect power source and turn the vehicle ignition (make sure this connect with “Signal”) to test the unit.
- Observe completion of the unit power-up procedures as described in section labeled as “System Startup and Shutdown”.
- Apply any information labeling required by local statute for video surveillance.

II-9 MDR Installation Layout

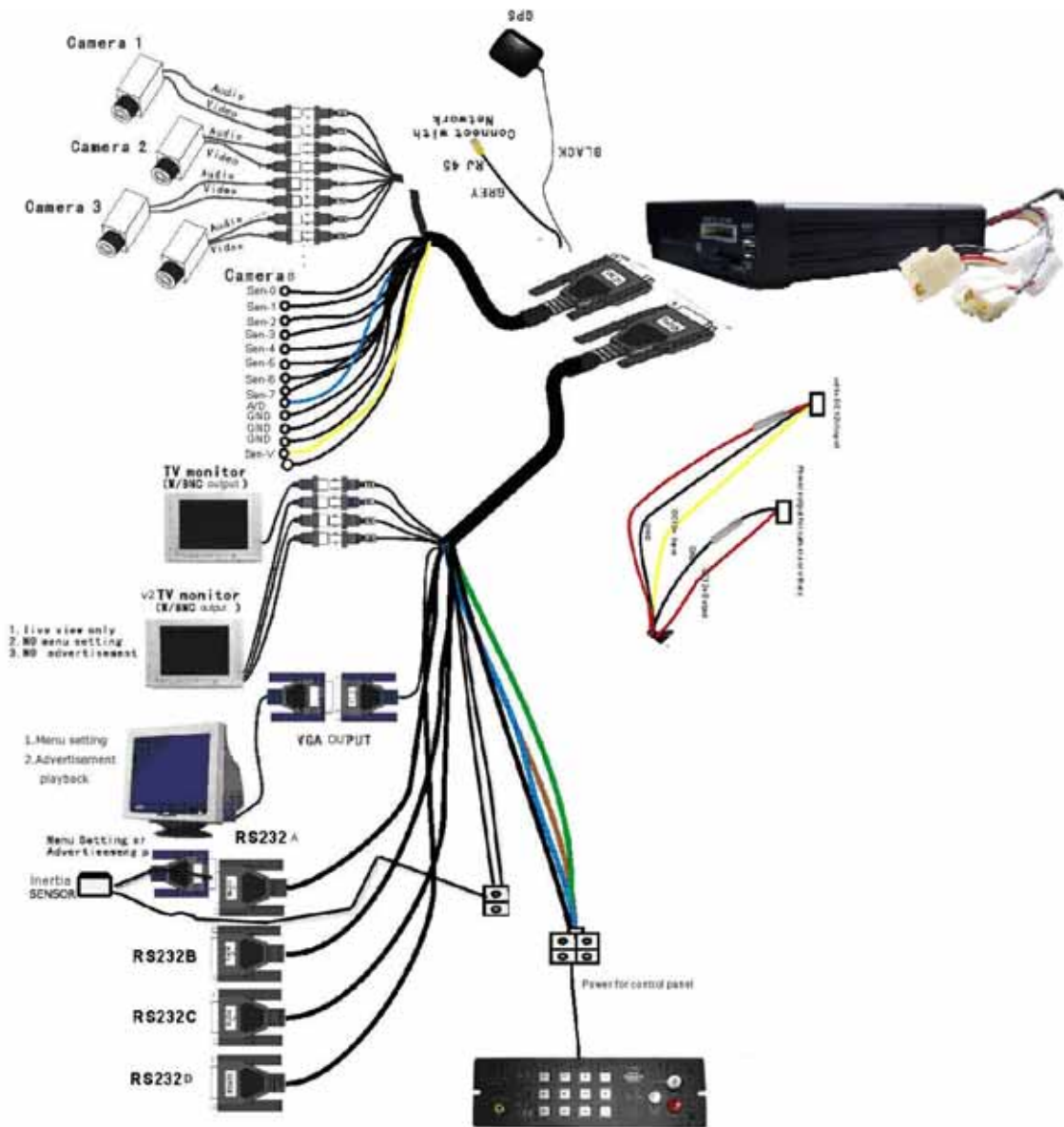

Note: This is a sample I/O Schematic. Sensors are not reserved for any device. Sensors can be connected to any external device in any order. The label in the setup differentiates the sensors connected to the I/O.

II-10 MDVR Bridal Connection Guideline

DC IN:

The bridal description for the power cable supplied with MDR is as follows:

Color coded wire	Description
INPUT (Red)	Positive wire. Should be connected to the positive terminal of the battery
INPUT GROUND (Black)	Negative (ground) wire. Should be connected to the negative terminal of the battery
SIGNAL (Yellow)	Connect with car ignition to let the system start up (need provide +ve DC power as signal ON/OFF)

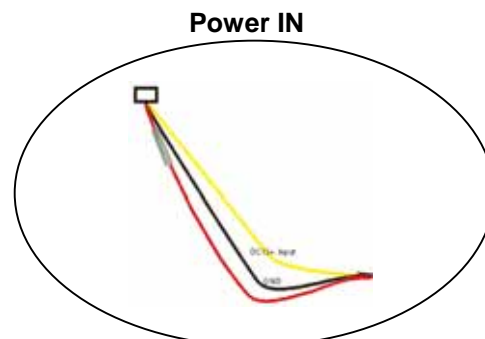

ⓘ Remark: Please make sure to power up the "signal"(yellow) input
Without signal "ON" the MDVR will not turn on.

DC OUT:

The bridal description for the power cable supplied with MDR is as follows:

Color coded wire	Description
OUTPUT (Red)	Positive Power wire, provide the power to camera or other device. (the voltage directly draw from "POWER INPUT" bypass the MDR)
OUTPUT GROUND (Black)	Negative (ground) wire, provide the power to external device or equipment

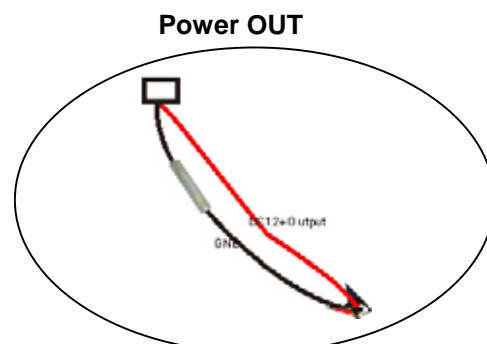

ⓘ Remark : The voltage output is directly by-pass voltage input level.
e.g, Input +12VDC, output voltage +12VDC;
If Input +24VDC, output voltage will be +24VDC
Please check voltage before connect with camera avoid burning out the camera.

Input Bridal DB37 (Video/Audio IN/ Sensor Input):

The bridal description for the Input bridal supplied with your MDR is as follows:



Label	Description
V 1	Video input for camera number 1
V 2	Video input for camera number 2
V 3	Video input for camera number 3
V 4	Video input for camera number 4
V 5	Video input for camera number 5
V 6	Video input for camera number 6
V 7	Video input for camera number 7
V 8	Video input for camera number 8
A 1	Audio input for camera number 1
A 2	Audio input for camera number 2
A 3	Audio input for camera number 3
A 4	Audio input for camera number 4
A 5	Audio input for camera number 5
A 6	Audio input for camera number 6
A 7	Audio input for camera number 7
A 8	Audio input for camera number 8
Color coded wire	Description
Sen 1 (Red)	Sensor 1 (0~36 V) input
Sen 2 (Red)	Sensor 2 (0~36 V) input
Sen 3 (Red)	Sensor 3 (0~36 V) input
Sen 4 (Red)	Sensor 4 (0~36 V) input
Sen 5 (Red)	Sensor 5 (0~36 V) input
Sen 6 (Red)	Sensor 6 (0~36 V) input
Sen 7 (Red)	Sensor 7 (0~36 V) input
Sen 8 (Red)	Sensor 8 (0~36 V) input
A/D -IN2(Green)	Enable the Analog to Digital input
Sensor-INV	Connect with Speed Sensor

Output Bridal DB25 (Video/Audio Out/ RS232/ Inertia Sensor/ Control Panel):

The bridal description for the Output bridal supplied with your MDR is as follows:



Label	Description
V1	Composite output for controlling MDVR. IR handheld is fully functional when connected to V1 output
V2	Composite output for live camera view only. IR handheld is not operational when connected to V2 output
AL	Left Audio output
AR	Right Audio output
VGA	VGA output for controlling MDVR. IR handheld is fully functional when connected to VGA output
RS232A	For Inertia Sensor connecting
RS232B	Steering and device data output (hyperlink)
RS232C	PTZ / ID card reader
RS232D	Reserve for future use
4 Ping	Connector for control panel connecting
2 Ping	Connector for power to Inertia sensor

① **Remark: PIN Definition (DB37 and DB25) shown in Appendix A**

GPS Antenna (Optional):

- MDVR is capable of embedding GPS coordinates and speed on the video.
- MDVR uses a passive GPS technology which does not require any service subscription from local service provider.
- Passive GPS receives the signal from satellite as latitude, longitude and speed after negotiating with the satellite. It takes approximately 3-5 minutes after boot up to start the negotiation process with the satellite to receive the signals. When the negotiation is completed a graphical icon at the live display shows the availability of GPS.
- If the negotiation fails an X is marked on the graphical icon showing the failure of satellite communication.
- This GPS option can provided the time synch features for MDR device;
- Connect the GPS antenna provided with your set (if ordered GPS equipped DVR) and hang it such that the front of the antenna is upwards facing the sky.



Network Connection (RJ45):

- Using the network cable to link with MDR to network system, allow browse into the system using client software or remote access to MDR;

II-11 MDR Visual Orientation

Front Panel (Recording Module):



0. **2 USB 2.0 Connectors:**

To upgrade the MDR firmware/Ads and transfer files with use cable from OR to PC, via Device OR Host Mode in USB operation. **USB Port:**

1. **CF Card Slot:**

To upgrade the MDR firmware/Ads and transfer files without the use of a PC, use an industry standard Compact Flash card. For uploading instructions refer to section labeled as “CF card Operation and Function”

2. **IR Receiver Lens:**

Please ensure that the MDR is installed where the handheld IR controller can be pointed directly to the IR receiver lens. Point your handheld controller at the spot on the recording module allowing the unit in responding to commands from the controller.

3. **LED Indicator and Status Display:**

[10M/100M](green) Network connection speed: LED ON for 100M bps, LED off for 10M bps.

[LINK/ACT] (red) Network connection activity light: LED blinking indicates data transfer.

[HDD](yellow) Hard disk drive activity: LED ON indicates system is reading/writing to hard disk.

[REC] (red) Video recording status: LED ON indicates recording is on for at least one channel.

[ALM] (red) Alarm status: LED ON indicates unit is currently responding to an alarm condition. Alarm can be caused by an external sensor trigger, hard disk failure and video loss

[POWER] (red) Input power status: LED ON confirms that unit is powered.

[ERR] (red) Error status with USB connection: LED blinks while USB connection problem occur.

[ACC] (yellow) USB connection status: LED blinking indicates data transfer using USB port.

[CF] (green) CF card status: LED ON indicates that CF card is inserted and the data is accessible.

ⓁNotice: when the [ALM] on, caused by video loss or trigger “High Speed Limit” sensor, require login as administrator or press **【Enter】** (set PASSWORD ON) to disable the alarm LED and buzzer from control panel;

ⓁRemark: CF card MUST BE formatted to FAT32.also, using “San disk/ Kingstone” type of CF card for recommending

Back Panel Layout (Docking Module):



Rear Connections (Mounting Assembly):

All connections to the MDR are attached to the rear of the Mounting Assembly using pre-assembled bundles of wire specifically labeled for each purpose, It include 6 parts as below:

0. Network connection port (RJ-45)
1. GPS Antenna Connection
2. DB25 : Audio/ Video Signal outputs/ VGA/ RS232/ Inertia connection / Control Panel connection/ID card
3. DB37 : Audio/ Video Signal Inputs/ Sensors connections
4. Power INPUT and OUTPUT Connections

Disconnecting a bridal does not affect the operation of remainder of the MDR functions

II-12 Handheld IR Remote Controller Functions

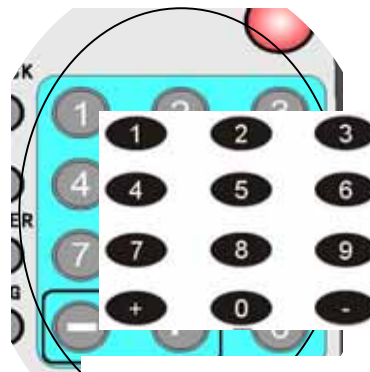
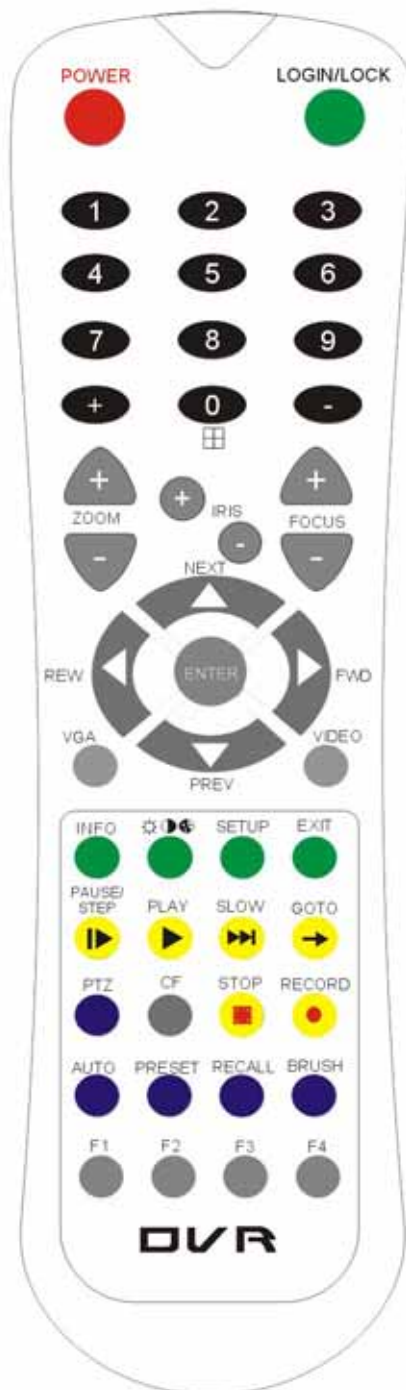

Numeric Input Keys

Use the numbers to input values in the system setup screen or switch through the channels in live and playback. Plus and Minus is used to increase setup values one by one.

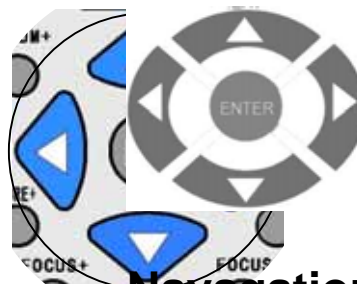

Navigation Arrows

Use the ARROW keys to move between selections, input fields and icons. Press ENTER to select data fields, and icons. Press ENTER to select and previous is also used to increase or decrease volume when at live or search screens. Press EXIT to return.

Each MDR includes a handheld Infra-Red (IR) controller that allows the user to transmit commands to recording module and display on screen control menu either on a composite monitor (V1 output) or a regular monitor (VGA).







Handheld IR Controller Key Functions:

1. Numeric Keypad:

[0-9] keys: During setup, number keys are used to input values.

For viewing channels 1, 2, 3 and 4 use 1, 2, 3 and 4 on numeric keypad respectively.

[+], [-] keys: During setup, plus and minus are used to select next or previous values.

During real time view of individual camera, after you pressed    key use plus and minus to make the color adjustments. Pressing    will navigate through the color adjustment options. Please be advised that the unit needs to stop recording before any color adjustments are made.



2. Setup Menu Navigation:

▲, ▼: Up, Down directional keys: Moves selection up and down in setup menu.







▶, ◀: Left, Right directional keys: Moves cursor left or right in setup menu.

[ENTER] key: During setup, select and save entry
During Playback, displays the channel name, text number, driver name, event sensor item and time on the screen

3. Other Key Functions:

LOGIN/ LOCK	If the security is enabled in the setup, use LOGIN / LOCK or SETUP key to enter the user setup. It is important to remember the password due to without restoration function.
POWER	The Power button can reset the DVR in to sleep mode (unit will stop recording while in the sleep mode)
VGA	Switch the output mode to VGA(Include: VGA1,VGA2,VGA3)
VIDEO	Switch back from VGA to composite output (V1)
	Swapping between multi-channel and single channel monitor while in surveillance screen only. Press this button to change the number of display channels. By pressing the key, display channel change in the sequence of four→one→two→three→four
	Brightness, contrast, color adjustment per channel. Use [+] [-] button to change the values. User can adjust the values for each channel individually.
SETUP	System setting screen (may require login)
EXIT	Returns to the previous menu. Pressing exit key takes one step back in the until the live monitor screen is displayed
Stop	Used to stop the recording manually.
Record	Used to start the recording manually.

3. Other Key Functions (Continue):

PAUSE/STEP 	Freezes playback to a single frame and can advance one frame at a time. To advance the frame press Pause / Step to move frame by frame. Press EXIT to return to normal playback speed
PLAY 	Starts/Resumes playback from any other mode (FF, RR, Frame by Frame etc)
SLOW 	Reduces playback speed to 1/2, 1/4, 1/8 modes. Press PLAY to return to normal playback speed
GOTO 	Quick search mode within the file playing back. Select the desired file and start to play. Press GOTO button and input the desired time. Select START to jump to the specific time
NEXT 	Increase volume while playback (if audio is recorded) or multimedia playback
PREV 	Decrease volume while playback (if audio is recorded) or multimedia playback

REW	◀	Rewinds the video while playback. X2 and X4 modes available
FWD	▶	Fast forward the video while playback. X2 and X4 modes available
CF		While CF card inserted, this button can activate the CF function
[F1], [F2],[F3],[F4]		Reserved for future use

4. Pan/Tilt/Zoom Function Controls:

While connect with PTZ camera and using the RS485a/b, following command can control with PTZ camera with following function:

[ZOOM IN +], [ZOOM OUT -]	ZOOM IN/OUT
[IRIS +], [IRIS-]	IRIS control
[FOCUS +], [FOCUS -]	FOCUS IN/OUT
PTZ	Start to active the PTZ function
AUTO	Auto run with the PTZ pattern
PRESET	Preset default position
RECALL	Recall the set program
BRUSH	Brush the glass screen

Troubleshoot:

Check battery in place of remote control

III. System Start-up/ Shut down

1. System Start Up

After connecting the MDR to a vehicle power supply turn on the vehicle ignition and the unit will automatically start recording. Power is normally supplied to the MDR as long as the vehicle ignition is ON. Start-up process completes as follows:

- “Display only view” of the cameras is immediately available to be viewed through Video Output 2 in quad view.
- “Auto-display view, Customer LOGO view and Administrative view” of the system is available to be viewed through Video Output 1. Recording video signal and Advertisement display play continuously as long as the power supply is not shut down. It could not stop the recording When the power supply is shut down.

2. System Login for Setup Functions

- When Password is set disable, press SETUP key on the handheld controller into the setup menu directly;
- When Password is set enable, press LOGIN/LOCK OR ENTER key on the handheld controller, the setup menu will appear:

Please enter Unit ID & password:

Unit ID : (00000)

Password:

Enter Cancel

- OPERATOR PASSWORD CORRECT indicates permission is limited to video, sensor menu.
- ADMIN PASSWORD CORRECT indicates full access to MDR.
- SUPER PASSWORD CORRECT indicates full access to MDR under the circumstance of forgetting the password and amend the MAC address.

Remark: Default password for Admin/user : 8888 8888

Super password only available from your distributor or manufactory

3. Control of System Operations

Press **SETUP** on the IR controller, then login to the system the on-screen menu will be displayed:

- Navigate through the option using the **ARROW** keys
- Select the desired option using the **ENTER** key
- To turn to the previous menu from any screen use the **EXIT** key



IV. MDR system layout

IV-1 Advertisement

- A. To administer Advertising files use **ARROWS** to select  and press **ENTER**

The screen will show the menu as below:

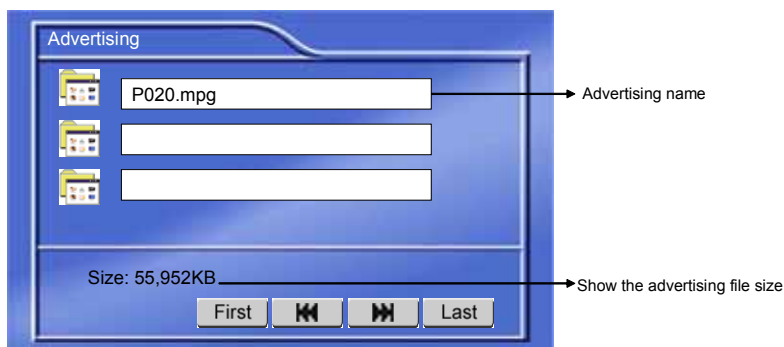

- ◆ **Play:** select the advertising file and press [Enter] to play. While the advertising is playing, the Handheld IR navigation keys (▲/▼,◀/▶) increases / decreases or the Page up/Page down the volume. Press [⏸] will pause the advertising clips. Pressing the [▶] key will resume the playback. Press [EXIT] return to the advertising menu.
Remark: While the advertising is playing, all the files must be the same format and no interval file
- ◆ **Delete the file:** Select the file to delete and press the right direction key [▶]. The screen will show a confirmation dialogue as below:

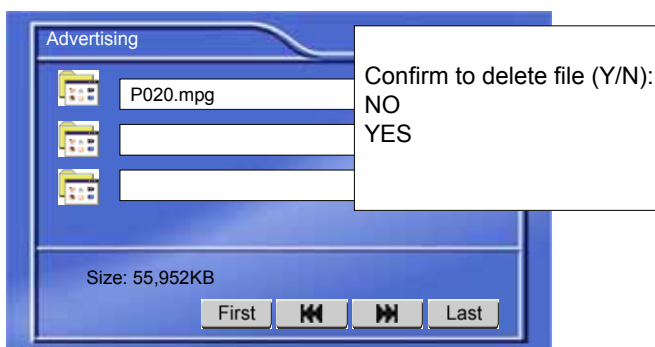

- ◆ Select "NO" and press "ENTER" to cancel the delete operation.
- ◆ Select "YES" and press "ENTER" to delete the file you have selected. Note that once the file is deleted it cannot be recovered.
- ◆ Press [EXIT] to return to the main menu.
- ◆ **Search the file:** There are a few buttons at the bottom of the screen. Use [] , [] , [◀], [▶] key to select the first page, next page, previous page, last page.

IV-2 MUSIC

- A. To administer Music files use ARROWS to select  and press ENTER

The screen will show the menu as below:

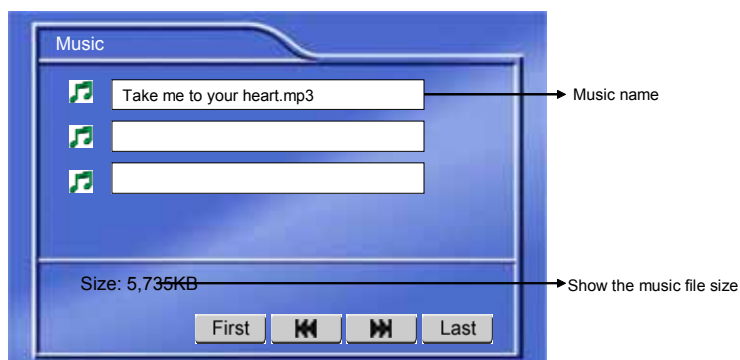

- ◆ **PLAY:** Select the music file and press [Enter] to start playing the file. While the music is playing, the Handheld IR navigation keys (▲/▼,◀/▶) increases / decreases or the Page up/Page down the volume. Pressing [] will pause the music. Pressing the [] key will resume the playback. Press [EXIT] return to the music menu.
- ◆ **Delete the file:** Select the file to delete and press the right direction key [▶].
- ◆ Select “NO” and press “ENTER” to cancel delete operation.
- ◆ Select “YES” and press “ENTER” to delete the file you have selected. Note that once the file is deleted it cannot be recovered.
- ◆ Press [EXIT] to return to the main menu.
- ◆ **Search the file:** There are a few buttons at the bottom of the screen. Use [], [], [◀], [▶] key to select the first page, next page, previous page, last page.

IV-3 MOVIE



- A. To administer Movie files use ARROWS to select **Movie** and press ENTER

The screen will show the menu as below:

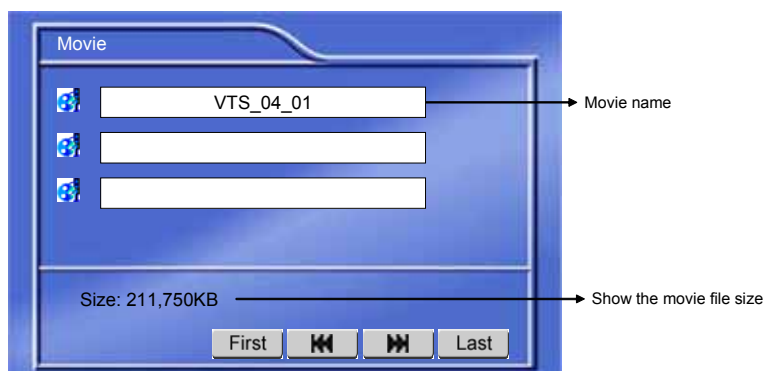

- ◆ **PLAY:** Select the movie file and press [Enter] to start playing the file.
- ◆ While the movie is playing, the Handheld IR navigation keys (▲/▼,◀/▶) increases / decreases or the Page up/Page down the volume. Pressing [] will pause the movie. Pressing the [] key will resume the playback. Press [EXIT] return to the music menu.
- ◆ **Delete the file:** Select the file to delete and press the right direction key [▶].
- ◆ Select “NO” and press “ENTER” to cancel delete operation.
- ◆ Select “YES” and press “ENTER” to delete the file you have selected. Note that once the file is deleted it cannot be recovered.
- ◆ Press [EXIT] to return to the main menu.
- ◆ **Search the file:** There are a few buttons at the bottom of the screen. Use [], [], [◀], [▶] key to select the first page, next page, previous page, last page.

IV-4 SEARCH



- A. To search the recordings use ARROWS to select **Search** and press ENTER

Enter the required information on the screen. MDR selects the current date by default.

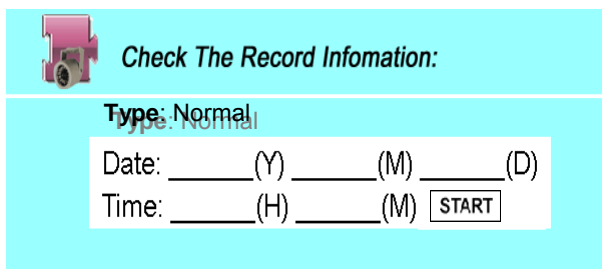

The oldest record time: 09/25/2005

Type : Normal/Alarm

Normal recording is the recording when no alarm occurs;
 Alarm recording is the recording when alarm occurs.

e.g: If the recording is triggered by sensor, meanwhile the alarm is set as ON, such as the following interface (the red fonts):

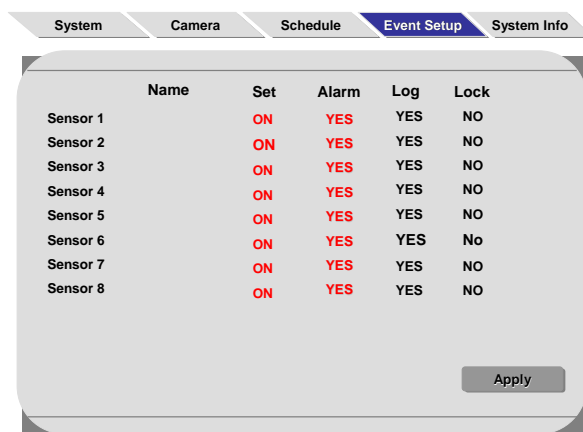

The main screen allows the user to enter the specific dates for the playback. “The oldest record time” is a quick reference for the oldest recording available to MDR. Using the numeric keypad and ARROW of the handheld IR controller or [+] [-] keys to increase the values, fill the appropriate data:

- “Year”: Range is 2000 to 2099. Only the last 2 digits of the year are changeable (Ex: “03” for year 2003), also could use [+], [-], [Enter] key to increase and decrease digits;
- “Month”: Range is 01-12 for the corresponding month number, also could use [+], [-], [Enter] key to increase and decrease digits;
- “Day”: Range 01-31 for the corresponding day of the recording, also could use [+], [-], [Enter] key to increase and decrease digits;
- “Hour”: Range 00-23 for the appropriate hour to begin the search, also could use [+], [-], [Enter] key to increase and decrease digits;
- “Minutes”: Range 00-59 to narrow the search, also could use [+], [-], [Enter] key to increase and decrease digits;

Press Setup on the hand held IR remote to get the calendar. The yellow color indicates the days of recording. The blue color indicates no recording.

Remark: the date is just for selected month.

1	2	3	4	5	6	7	8	9	10	
11	12	13	14	15	16	17	18	19	20	
21	22	23	24	25	26	27	28	29	30	31

After entering the start time move to the “START” and press “ENTER” on the handheld IR controller. The recorded video history beginning at the time chosen will be listed on the screen.

Use the arrow keys to advance to the starting time. Select the entry and press "ENTER" to playback the video file. Press [EXIT] to return to the Previous Menu.

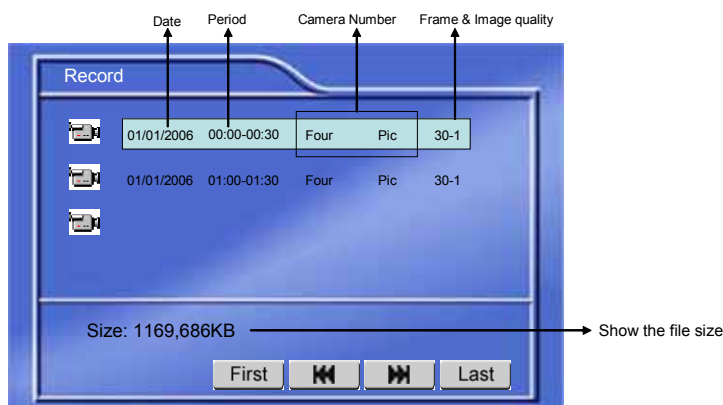

While the selected video file is playing back, user can select the video to jump to the specific time in the clip.

- Press "Goto" on the handheld and a selection bar would appear at the top left of the screen with a reference point about the length of the clip. The picture as below:
- Input the desired time and select "Start" to go to the required minute.



While the video is playing back, pressing "Enter" on the IR will show the associated text on the channel and pressing "Enter" again will hide the text giving a clear picture to view. The text on the video shows the following fields:



- camera --Camera name
- VID—Vehicle Number
- DID – Driver Name
- xxxx N, xxxx E, xxx KPH -- GPS coordinates (if available)
- Date
- Time
- Sensor label (if sensor was activated in the setup and sensor activity happens, the user definable sensor labels get embedded on the video for 10 seconds)

IV-5 EVENT



A. To search for events use **ARROWS** to select **Event** and press **ENTER**

The screen below will display sensor triggered events. Scroll down the list with the **ARROW** keys to find the event you wish to play. After the entry is highlighted press **ENTER** to play the video.

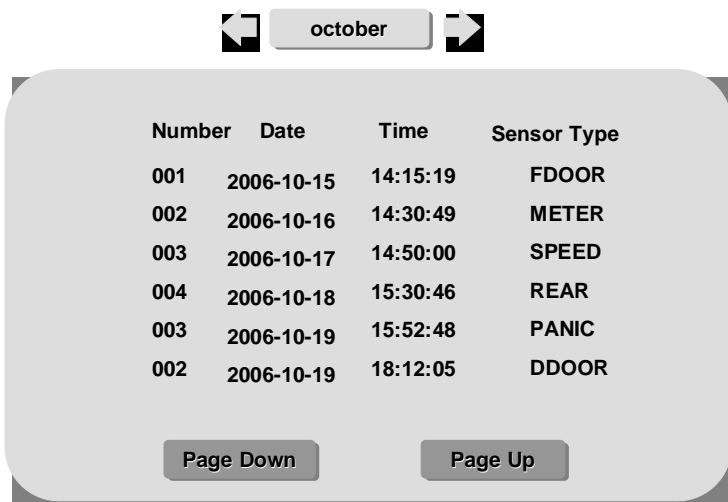

While the video is playing back, pressing “Enter” on the IR will show the associated text on the channel and pressing “Enter” again will hide the text giving a clear picture to view. The text on the video shows the following fields:

- camera --Camera name
- VID—Vehicle Number
- DID – Driver Name
- xxxx N, xxxx E, xxx KPH -- GPS coordinates (if available)
- Date
- Time
- Sensor label (if sensor was activated in the setup and sensor activity happens, the user definable sensor labels get embedded on the video for 10 seconds)

Once the video associated with the event is finished playing back, the system displays the Fig 2.1 to select other event.

V. System Setup Management

V-1 System Setup



V-1.1 To access the **SETUP** menu, use **ARROWS** to select **Setup** and press **ENTER**, meanwhile, the recording stop.

The **SETUP** menu consists of eleven tabs. Each tab is designed to facilitate the performance adjustments preferred by the user.

1. **SYSTEM:** Press **ENTER** to change system setup information.
 - Use **ARROW** keys on the handheld IR controller to scroll through the list of items on the left column.
 - Press **ENTER** to select the option. The setting area will appear on the right column.
 - Press the **RIGHT ARROW** [**▶**] key to switch to the data entry area.
 - Press the **UP** [**▲**] or **DOWN** [**▼**] **ARROW** key to scroll through the entry fields.
 - Press the **ENTER** key to change the value or use the numeric keypad on the handheld controller for data entry areas where the numeric values are used
 - To save the changes, scroll to **APPLY** at the bottom screen and press **ENTER**.
 - Press **EXIT** to quit without saving changes

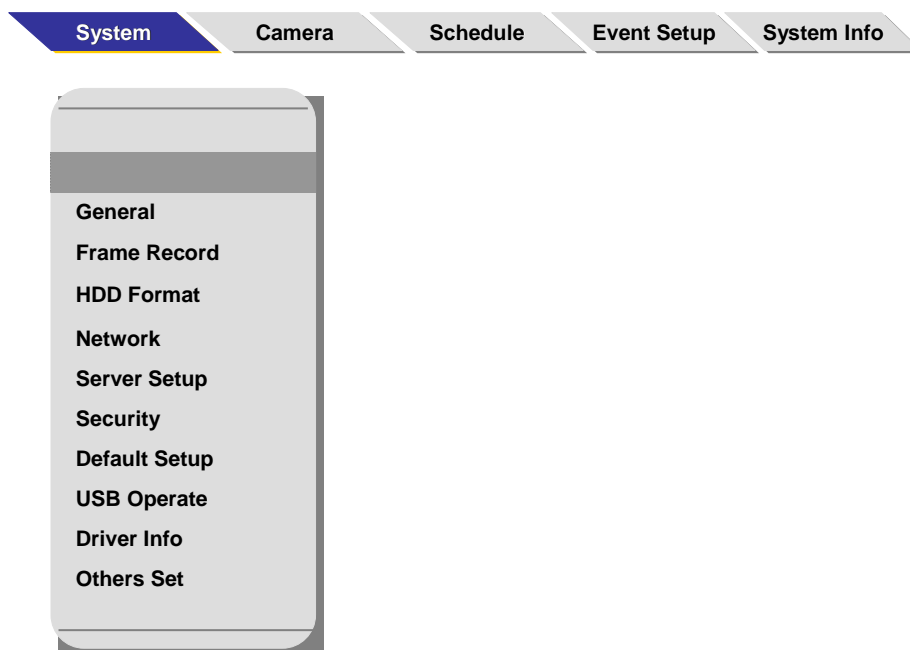

A) Date / Time.

Press **ENTER** to access input settings. Use **ARROW** keys to scroll through the options.

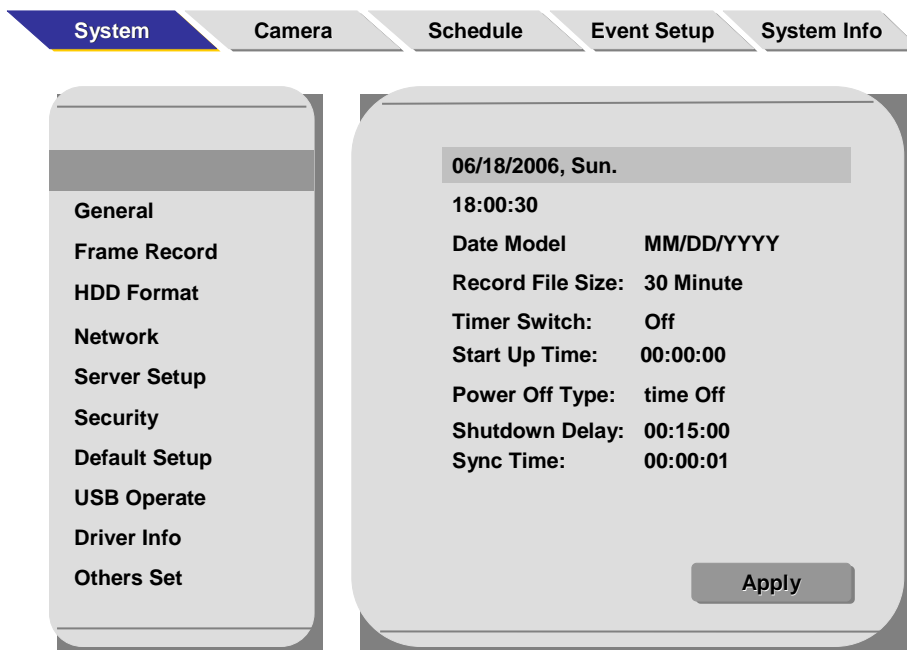

Date:	DD/MM/YYYY	Enter with number keys
Time:	HH/MM/SS	Enter with number keys
Date Mode:(US or Int's)		Press ENTER to switch between the date patterns
Record File Size:		Press ENTER to scroll through the settings. The record file size is used to break down the recording clips into smaller timings. The available selections are 15 minutes, 30 minutes, 45 minutes and 60 minutes.
Time Switch:		Used for the MDR can switch ON/OFF at specific time; mainly used for start up /shut down the unit.

Note: The following options will be available only when the time switch is ON

Start Up Time:		When Time Switch "ON", the system can start up at specific time every day, its can be allow perform following functions: <ul style="list-style-type: none"> ● Starting the recording function (when the schedule had setup continuous recording at this period), Use Numeric key to input time;
Power off Type: Time off/Delay off		Time off means the unit will shut down at the specific time--shut down delay ; Delay off means the unit will shut down after the delay time—shutdown delay .
Shutdown Delay:		Allow the system continuous running when vehicle turn off (ignition signal OFF), it provide up to most 24 hours delay shutdown. Use Numeric key to input time;

ⓘ Remark: when shutdown delay finished, this act as high priority to make system shutdown regardless any activities running at that moment (even content being uploading or downloading, the system will turn off eventually)

Sync Time: This is the time when the unit will sync the system time every day. The method depends on the setting on the Time sync's option:
System>>general>> time sync

Time Sync: The system allow have the time synchronizing via by either "GPS" or "NTP".

i. While selecting the "GPS", the device must have GPS connection and GPS signal must be have well reception signal . To set the date and time in DATE/TIME menu, and unit will record the time difference. Restart or update, unit will synchronize with GPS time once.

ii. While selecting the "NTP" (Network Time Protocol), the device must have network access connection and assign the NTP IP location; This process run at 6:30am local time while the system have network connection;

Scroll to **APPLY** and press **ENTER** to save the new settings.

B) General :

Press ENTER to access input settings. Use ARROW keys to scroll through the options.

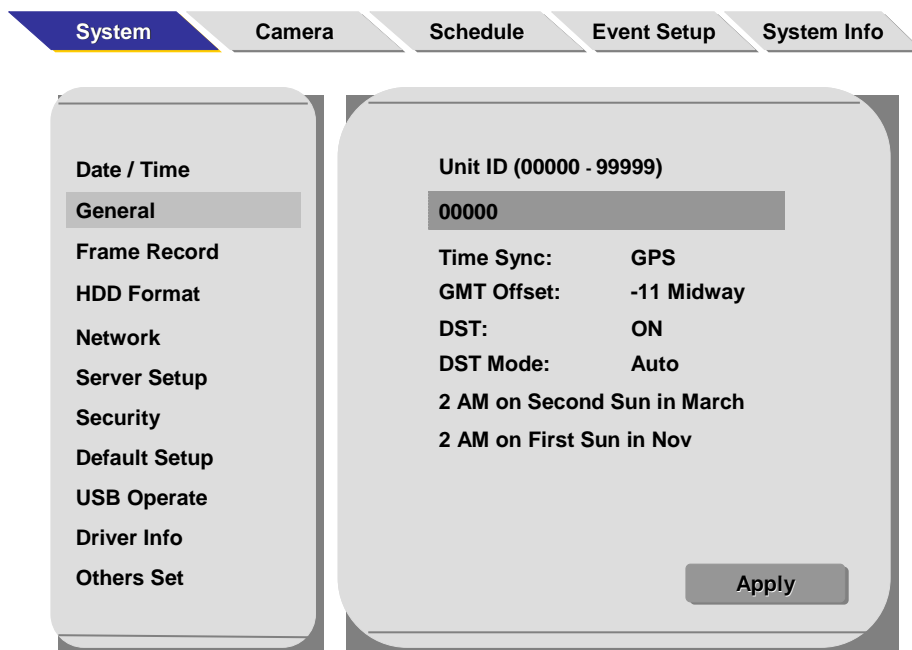

Unit ID (00000~99999):

Use the **NUMERIC** keypad to enter the unit ID between 00000 to 99999. This ID is used when logging in to the unit (if security is enabled (set as yes).

Time Sync:

The system allow have the time synchronizing via by either "GPS" or "NTP".

ii. While selecting the "GPS", the device must have GPS connection and GPS signal must be have well reception signal . To set the sync time in DATE/TIME menu, and unit will record the time difference-GMT offset, when the system time arrive the sync time, unit will synchronize with GPS time once.

- ii. While selecting the “NTP” (Network Time Protocol), the device must have network access connection and assign the NTP IP location; This process run at 6:30am local time while the system have network connection;

GMT offset:	This is the standard time area that to be sync for GPS.
DST: Daylight Time	Only when it set on, the following option will available.
DST Mode:	There are two modes: Auto/ custom. Auto: According to the international DST, i.e.: valid only between 2AM On Second Sun in March and 2AM On First Sun in NOV. Custom:the valid time is set according to the corresponding need;

Remark: While setting the DST, the former date must be smaller then the later date; if the two setting date is the same, the DST will invalid.

Scroll to **APPLY** and press **ENTER** to save the new settings. Press **[EXIT]** to return to the Previous Menu.

C) Frame Record:

Press ENTER to enable or disable Priority Record.

- Priority Recording records one frame per every second when no external sensor is sensed by the unit.
- When a sensor triggers through a sensor input, the unit automatically starts to record up to the user selected frames/second on all cameras.
- User can select between the timings before and after the event for high frame rate recording.
- Use the Numeric key pad or ARROW down to the second settings to define the time duration of full-rate recording after and before the trigger is over.

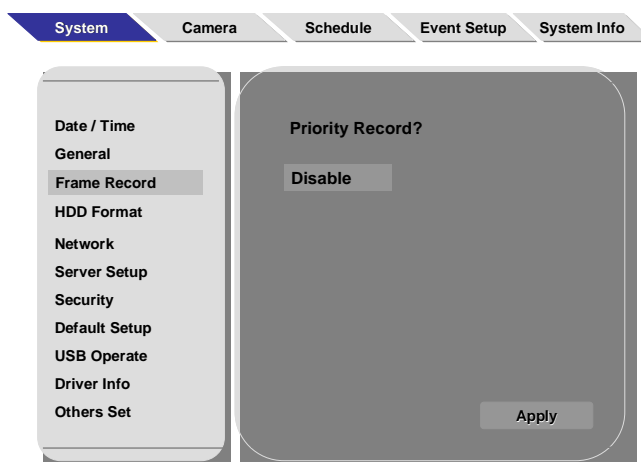

Scroll to **APPLY** and press **ENTER** to save the new settings.

D) HDD Format:

There are two options to chose from:

Format HDD: Formats the unit Hard Disk Drive

Format Compact Flash (CF) Card: Formats the CF Card

When START had been pressed, there are confirmation required from operator, select “Apply” to

proceed the hard disk formatting and "Cancel" to cancel the format operation;

D) HDD Format: (con't)

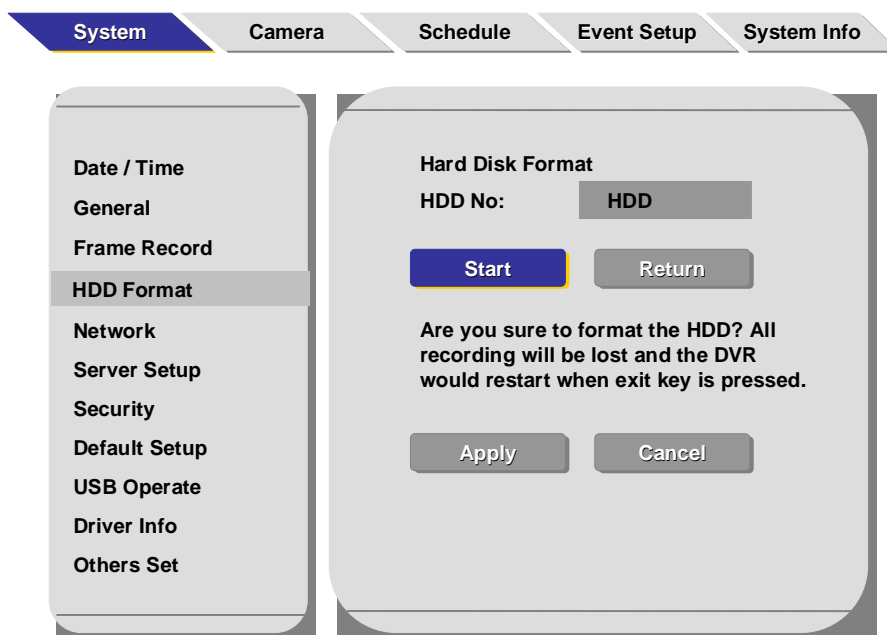

!! WARNING!! *Selecting START on this setting will erase all recorded video on the unit or the data on CF card Press ARROW keys to either choose START reformatting the disk or choose RETURN without formatting. Press ENTER to format. Press EXIT to return to the settings. The unit will re-start.*

E) Network:

Must enter a static IP address to use Network capabilities. Please consult with local Internet Service Provider for the information. Use NUMERIC keypad to enter the TCP/IP address

information:

Setup “IP address”: Enter the static IP address
Setup “Mask”: Enter the subnet mask
Setup “Gateway”: Enter the gateway

Center IP:

While using the CMS (Central Management System) software, require assigned the IP address to allow MDR can sending the video and data to this destination;

Port:

While using the Client software or CMS (Central Management System) software, require assigned the port for data transferring, recommend using port number 8000, 9000, 9100 (while the system already using those 7800 and 7801 for video and audio respectively);

Scroll to **APPLY** and press **ENTER** to save the new settings.

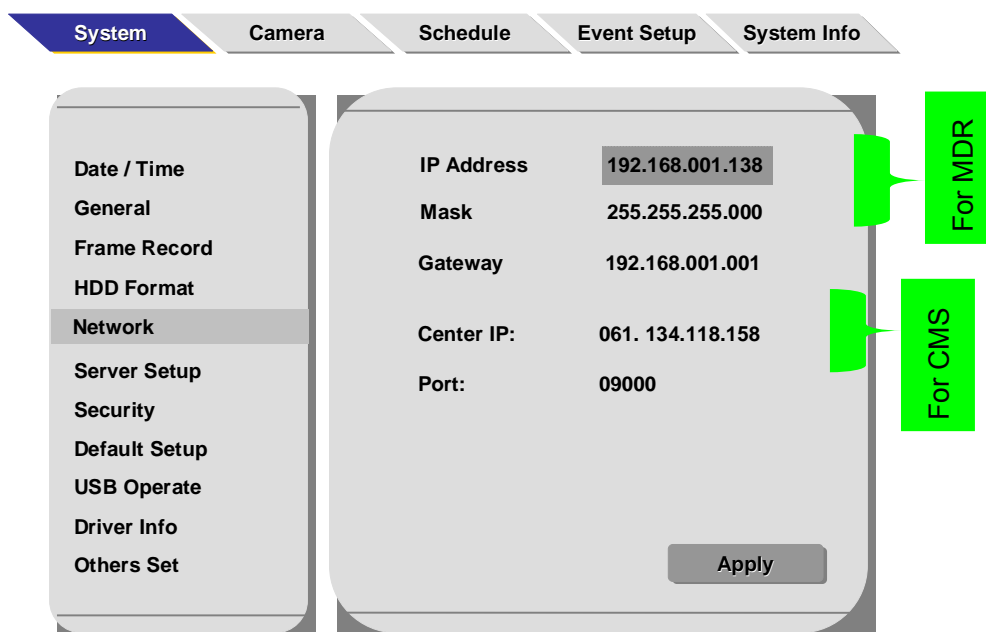

E.G: Apply in CMS (MDVR Connected with a EDGE router)

The default IP of EDGE router is 192.168.8.1, then the setting in Network should be set as below:

IP Address: Enter the static IP address: **192.168.8.xx**, "xx" can be any one between 2 and 254.
 Mask: Enter the mask: **255.255.255.000**
 Gate way: Enter the IP of the EDGE router: **192.168.8.1**

Center IP: Enter the IP of the PC in which installed the CMS server
 Port: Enter the gateway listen port of the gateway server in CMS.

Note : For CMS software, it's better to use EDGE router, if GPRS router, it can't transfer picture, only some data to transfer.

F) SERVER CONNECT: Means connect between Media Player Server and MDR

Press ENTER to access input settings. Use ARROW keys to scroll through the options.

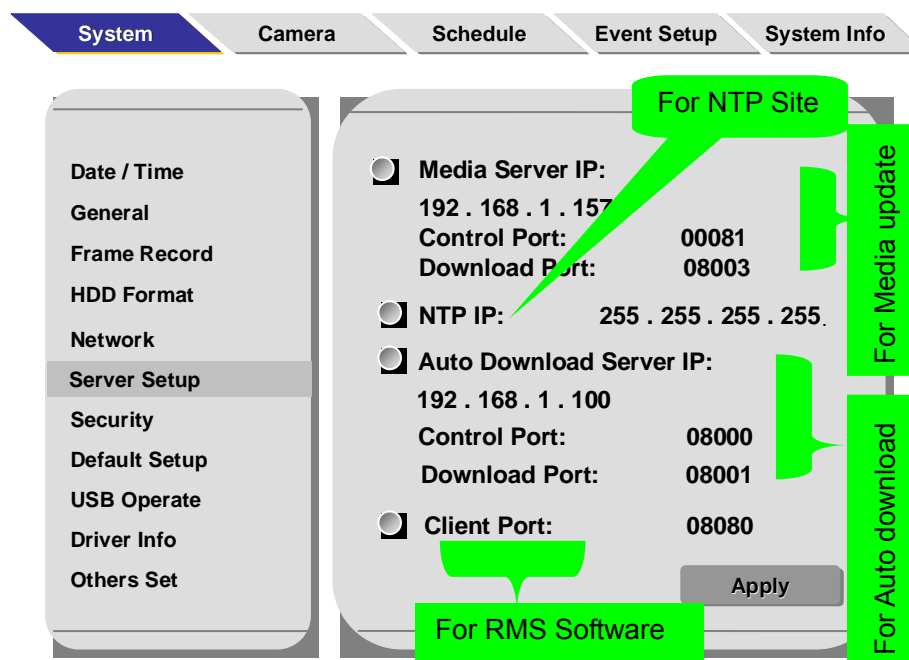
**Media Server IP:**

While using the media update server software, require assigned the IP address to allow MDR can updating the advertisement and other multimedia via network;

Control port:**Download Port:**

Each of the two ports must be the same of the corresponding one in media server software

User Name: The user name for operating the media server, default one is admin

Password: The password for operating the media server, default one is 8888 8888

NTP Server IP:

Input the IP server does support NTP protocol, in order to allow the system can have time synchronization through the network. [Example: "192.43.244.18", "129.6.15.28" "131.107.1.10", "132.163.4.101", "128.138.140.44", "69.25.96.13", "208.184.49.9"]

E.G: Apply in Media server (MDR connected to PC installed media server)

If the IP of PC in which installed the media server is 192.168.1.3, the control port in media server is 00080
The down port is 00081,the user name of media server is admin, the password is 8888 8888.

Then please set the setting in MDVR as below:

Media server IP: 192.168.1.3
Control port: 00080
Download Port: 00081
user name: admin
password: 8888 8888

Remark: the IP of media server and MDR must be in the same web field, that's to say, the 3rd field of their IP must be the same.

The two port mustn't be the same

Auto Down Server IP:

While using the auto download server software, require assigned the IP address to allow MDR can downloading the files to the server via network;

Control port:**Download Port:**

Each of the two ports must be the same of the corresponding one in media server software

E.G: Apply in Auto down server (MDR connected to PC installed auto down)

If the IP of PC in which installed the media server is 192.168.1.5, the control port in system setting of auto download is 8000; The transfer port is 8001,the user name of auto download server is admin, the password is 8888 8888.

Then please set the setting in MDVR as below:
 Auto down server IP: 192.168.1.5
 Control port: 8000
 Download Port: 8001

Remark: the IP of media server and MDR must be in the same web field, that's to say, the 3rd field of their IP must be the same.
 Control port mustn't be the same with download port.

E.G: Apply in RMS (MDR connected to PC installed RMS)

For RMS ,the corresponding port in MDVR is **Client port**
In RMS it self, you need add the IP of MDVR as following:

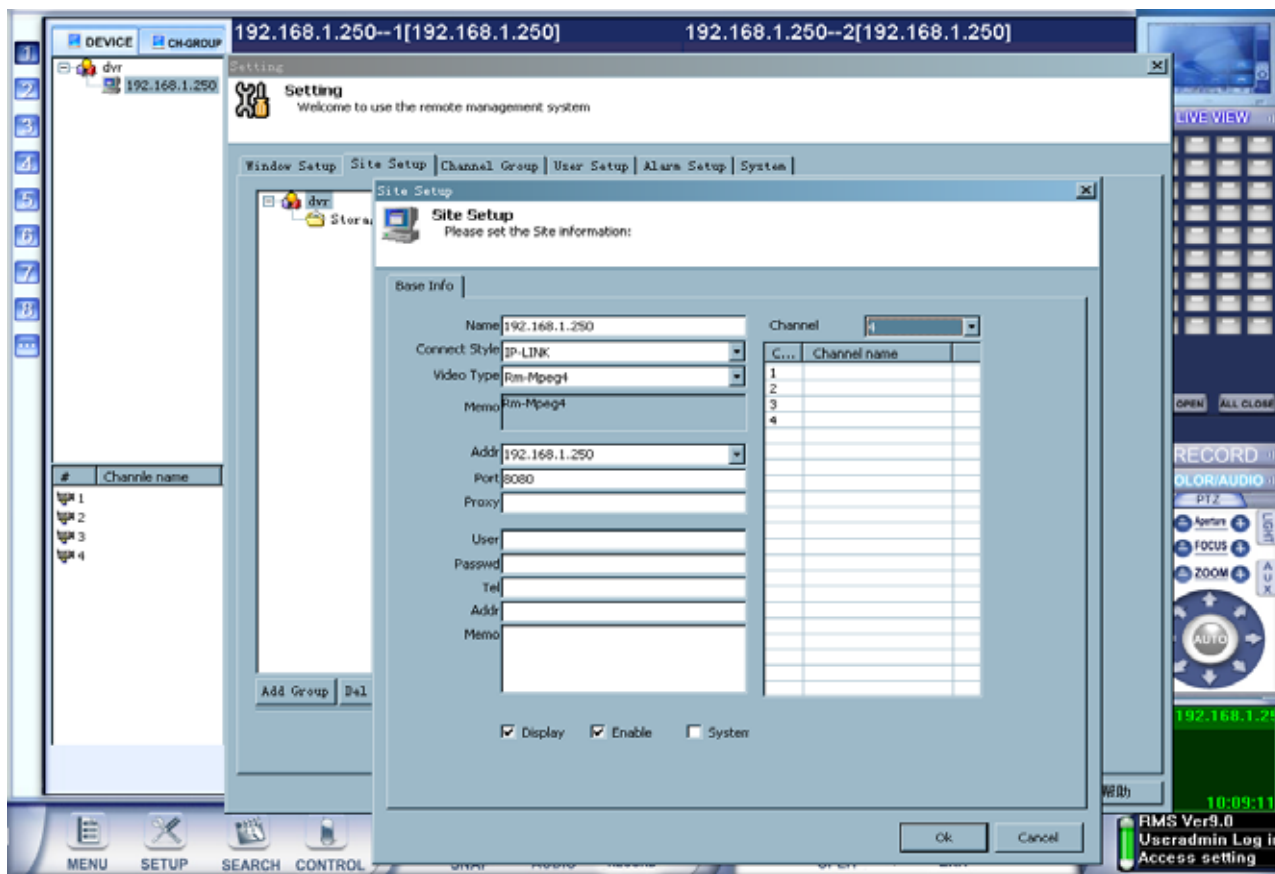

Scroll to **APPLY** and press **ENTER** to save the new settings.

G) Security:

Selecting "YES" will require a password in order to access the setup menu. Selecting "NO" will not require a password in order to access the setup menu.

- a. An Administrator with full rights and a User with only view playback and sensor rights can be created.
- b. Press ENTER to switch between "YES" and "NO".
- c. Press the down ARROW key to highlight the User password entry line. Enter the desired password and confirm. The password must be EIGHT NUMBERS long. Use the NUMERIC keypad on the handheld to input the values.
- d. Press the down ARROW key to highlight the administrator password entry line. Enter the desired password and confirm. The password must be EIGHT NUMBERS long. Use the NUMERIC keypad on the handheld to input the values.

Remark: The default password for user and admin is 8888 8888

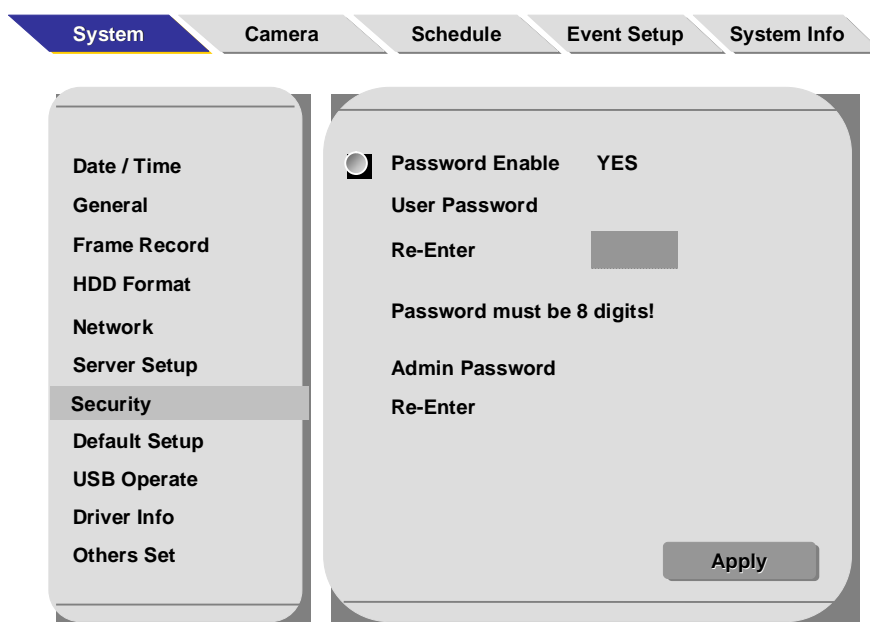

- e. **Re-enter:** must be same input as first password, otherwise the system would not accept the password setting when password does not match between first line and re-enter line.

Scroll to **APPLY** and press **ENTER** to save the new settings.

ⓘ Notice: The password would be corresponding to remote access software, which including CMS, Client software, auto download program.. etc. Must using same password to let the program access / operating device remotely;

?? Remark ??: In case forgot the password, please set the system with default setup. also you can contact with your local distributor for super password.

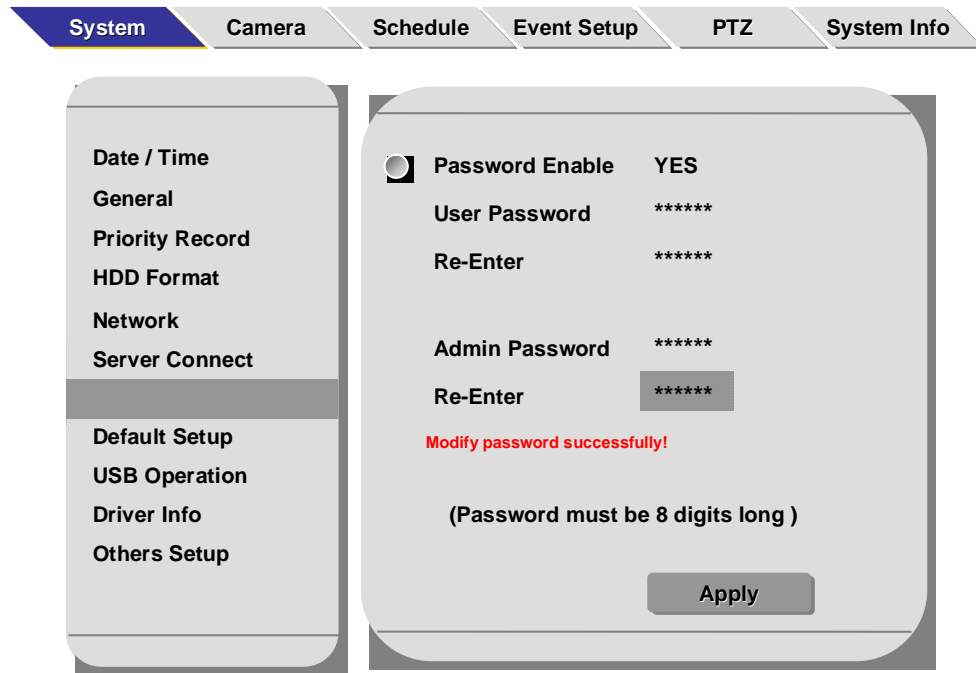

H) Default Setup:

User ARROW keys to switch between “Cancel” and “Apply”. Selecting “Apply” will restore the default factory settings.

!! Warning !!: Once the default setup had been loading, all the user setting had been delete and can not recoverd.

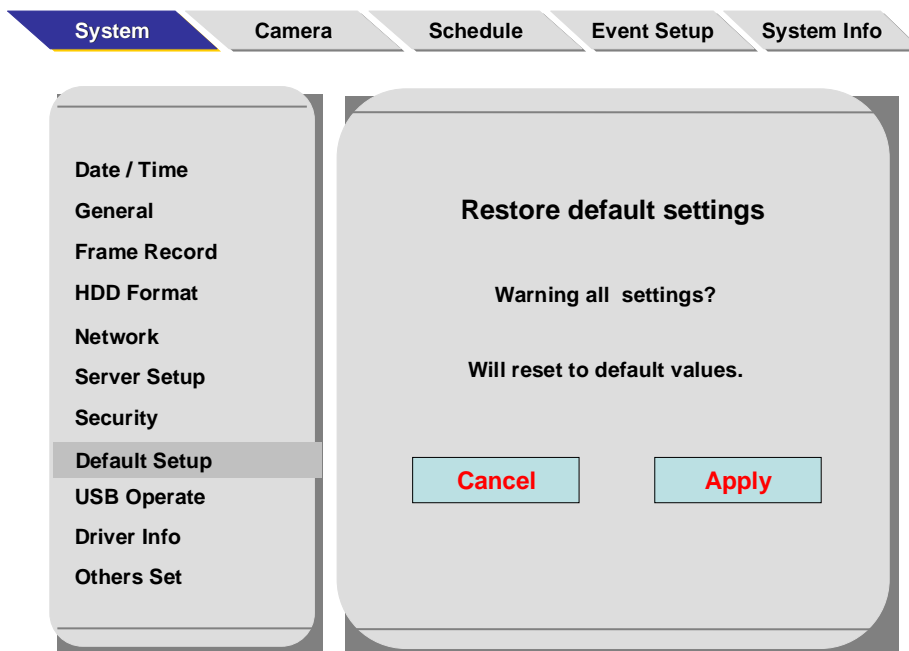

System Default settings:

Options	Default Setting		
System			
Date / Time	Current date and time		
Date Mode	MM/DD/YY		
Weekday Start	Monday		
Weekday End	Friday		
Time Sync	NO		
Daylight Time	NO		
General			
Unit ID	00000		
Record File Size	60		
Time Switch	ON		
Priority Record	Disable		
HDD Format	HDD		
Network			
IP Address	192.168.000.100		
Subnet Mask	255.255.255.000		
Gateway	192.168.000.001		
Server Connect			
Media Ctrl Port	00080		
Media Down Port	00080		
Auto Down Server IP	192.168.001.0601		
Ctrl Port	08000		
Down Port	08001		
User Link Port	65532		
Security	Yes		
USB Operation			
USB Mode Select	Device Mode		
Driver Info			
Company Name	XYZ		
Vehicle Number	123		
Driver Name	ABC		
Other Setup			
Video Display Type	NTSC		
Audible Alarm			
System Diagnostics	Yes		
Camera Failure	No		
Sensor Trigger	No		
Auto-Overwrite for HDD?	Yes		
Camera			
Camera 1	Label = No Label	Quality = 1	Audio = No
Camera 2	Label = No Label	Quality = 1	Audio = No
Camera 3	Label = No Label	Quality = 1	Audio = No
Camera 4	Label = No Label	Quality = 1	Audio = No
Camera Num	04		
Rate (FPS)	30		
Resolution	CIF		
Time Insert	ON		
Output Mode (only for Multimedia version)	Adver Autoplay		
Schedule	ON, Everyday: 00:00 – 23:59		
Event Setup			
Sensor 1	Off		
Sensor 2	Off		
Sensor 3	Off		
Sensor 4	Off		
Sensor 5	Off		
Sensor 6	Off		
Sensor 7	Off		
Sensor 8	Off		
X Sensitive (g)	0.2		

Y Sensitive (g)	0.2
Z Sensitive (g)	0.2
Spd Source	GPS
Spd check	000 000
Low speed Limit	000 KPH
High speed Limit	000

I) USB Operation:

There are two options available with the USB operation: **DEVICE MODE** and **HOST MODE**

DEVICE MODE:

Using the “ENTER” Key on the handheld IR select the “DEVICE MODE”. The “DEVICE MODE” allows a computer (or a laptop) to connect to the MDR via supplied USB cable. Once connected the drive appears as a regular hard drive in the computer. Normal Window operations could be performed (example: Download the recorded data from the unit to the computer hard drive, Upload the advertisement clips from the computer to the unit etc). For a complete file description of the MDR hard drive layout please look at following picture as “Hard Disk File Structure” .

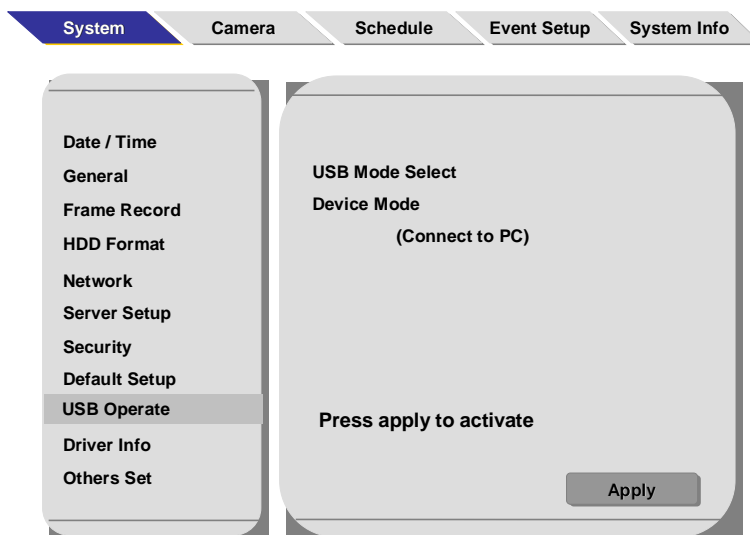

For a complete file description of the MDR hard drive layout please look at following picture as “Hard Disk File Structure” .

Hard disk file structure on PC:

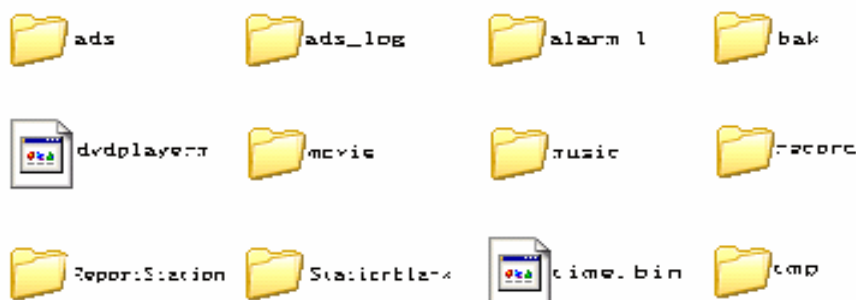

HOST MODE:

Using the “ENTER” Key on the handheld IR, select the “HOST MODE”. The “HOST MODE” allows an external USB jump drive to be connected. Once the connection is established, all the contents of the jump driver is automatically uploaded to the MDR “ads” folder. For a complete file description of the MDR hard drive layout please look at the chapter labeled as “Hard Disk File Structure” at the end of the manual.

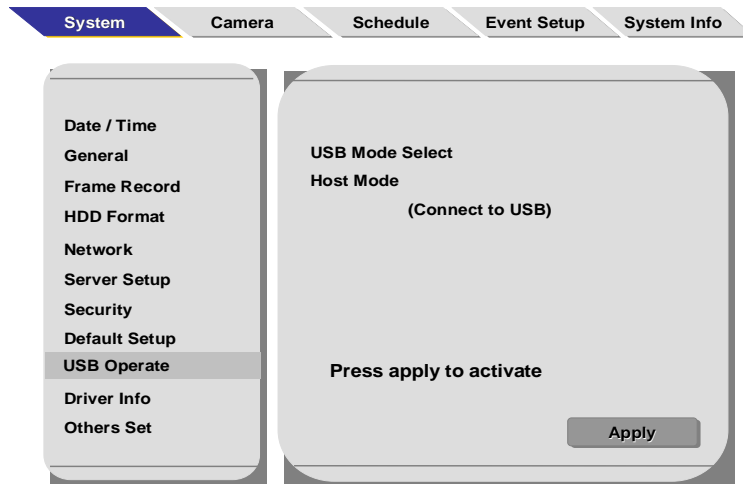

After USB operation: please press “Exit” then the MDR will re-start and back to the normal system operation;

Ⓜ NOTICE : For USB Operation: To maintain the live connection between Windows PC and MDR via USB cable, after apply ,the Device Mode menu screen needs to stay active. Exiting the option will interrupt the connection.

J) Driver Info:

The “DRIVER INFO” is used to store the following text information into the unit:

Company Name, Vehicle No. and Driver /Route Name.

Use **ARROW** keys to select the option for modification. Press **ENTER** at the highlighted line.

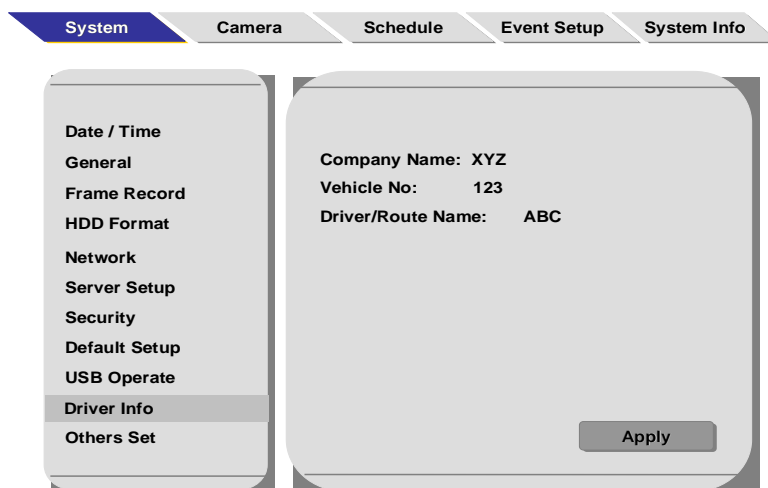

Remark: Vehicle No. is very important.

While using auto download software, the vehicle number is corresponding to the vehicle number plate in vehicle management interface of the software.

While using Media server, the vehicle number is corresponding to the vehicle number plate in car input interface of the software.

While using CMS(Central management system), the vehicle number is corresponding to the terminal number .

While using RMS(Remote management system), the vehicle number is corresponding to the terminal number .

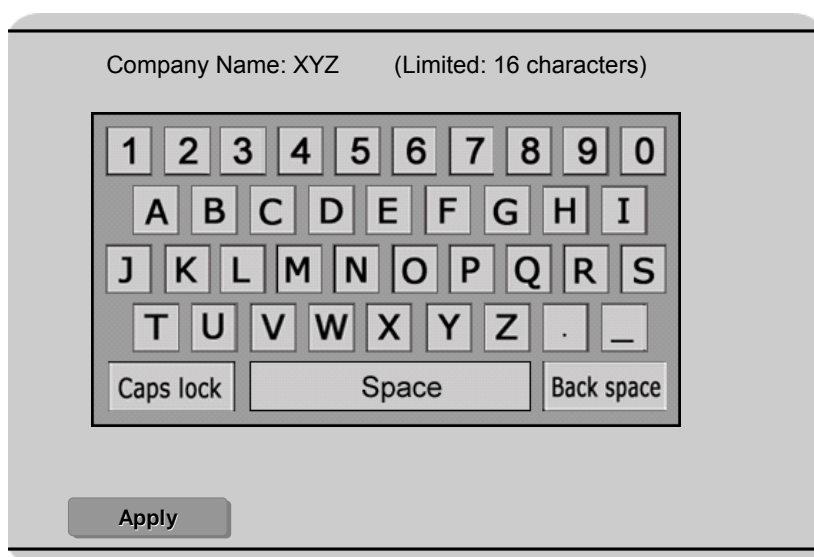

The screen will pop up a text entry keyboard. Use Arrows to choose characters, press ENTER to type. Scroll to **APPLY** and press **ENTER** to save the new settings.

Press **EXIT** to return to the SETUP list.

K) Others Set:

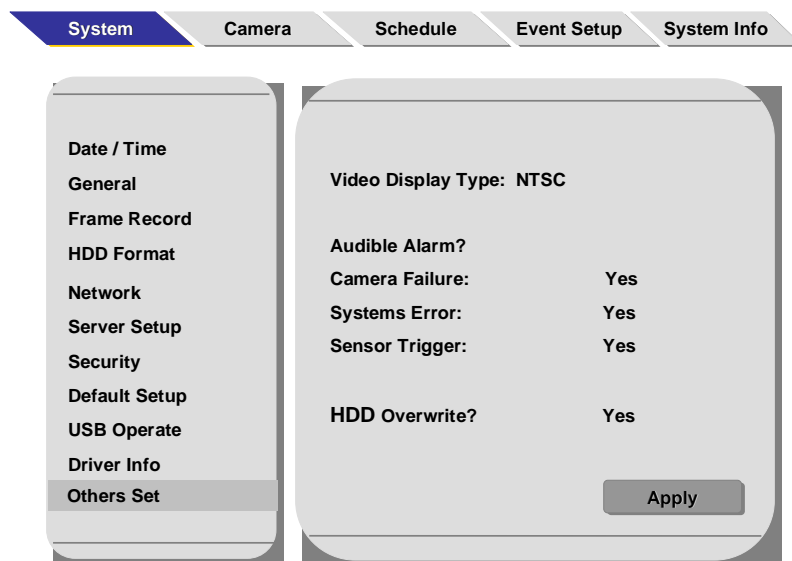

There are two options to choose from: press ENTER to switch between PAL or NSTC.

Audible Alarm only works for the buzzer, which installed in control panel.

Systems Diagnostics:

Select "Yes" : Buzzer will produce beeping when error occur in the system, press ENTER key of the Panel or login as Administrator, then the buzzer will stop beeping.

Select "No" : Buzzer will not produce beeping when error occurs in the system.

Camera Failure:

Select "Yes" : Buzzer will produce beeping when video loss, press ENTER key of the Panel or login as Administrator, then the buzzer will stop beeping.

Select "No" : Buzzer will not produce beeping when video loss.

Sensor Trigger:

Select "Yes" : Buzzer will produce beeping when Sensor Trigger occur, speed exceed SPD, XPD "Hign Speed Limit", press ENTER key of the Panel or login as Administrator, then the buzzer will stop beeping.

Select "No" : Buzzer will not produce beeping will not blink when Sensor Trigger occur, speed exceed SPD, XPD "Hign Speed Limit".

HDD Overwrite

Select "Yes" : When the remaining space is less than 2G, in order to leave the enough space for the new file, overwrite the earliest recorded file according to the rule of First-in First-out.

Select "No" : When the remaining space is less than 100M, the unit will not record until the HDD is changed or recorded file is deleted manually.

Scroll to **APPLY** and press **ENTER** to save the new settings.

V-2 Camera Setup

Camera Menu:

Press the RIGHT ARROW key to change control to the CAMERA tab. Press ENTER to open the Camera configuration screen.

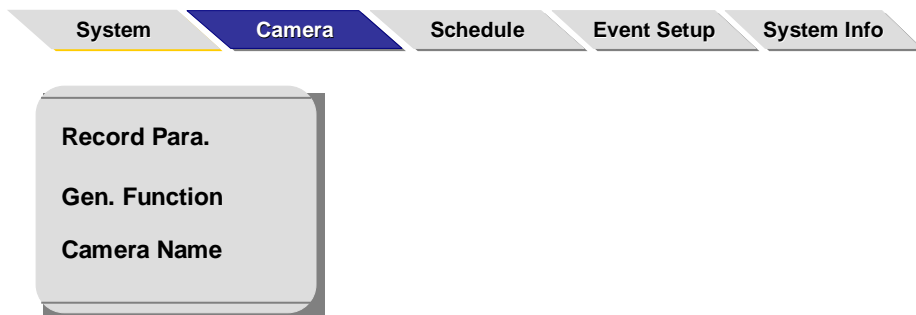

Press ARROW keys to move to each highlighted field and press ENTER to type into each field highlighted.

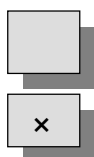
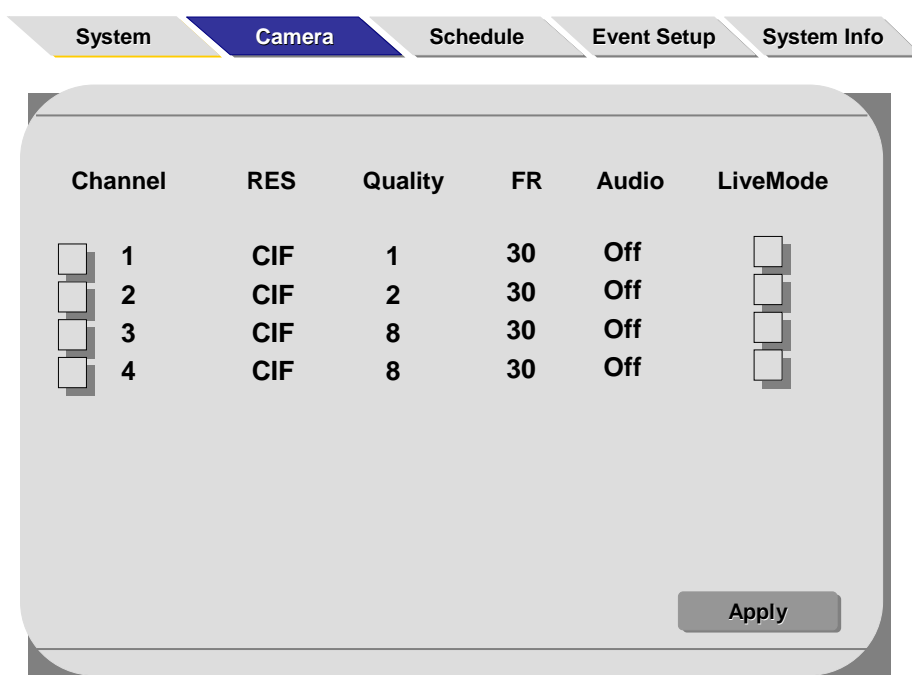

Means the channel is enable recording; Allow to view the livemode.

Means the channel is disable for recording; Does not allow to view the livemode.

Resolution:

Select among CIF, HD1 and D1:

- ◆ CIF: Resolution at 360x240 (NTSC), 352x288 (PAL)
- ◆ HD1: Resolution at 720x240 (NTSC), 704x288 (PAL)
- ◆ D1: Resolution at 720x480 (NTSC), 704 x 576 (PAL)

Quality:

Press ENTER to enter the recording quality (1 ~ 8)

Remark: 1 is the highest quality, high quality consumes more space. lower quality consumes less space.

F.R:

Press **ENTER** to choose between:

- ◆ 2, 4, 8, 15, or 30 frames/second (for NTSC)
- ◆ 1, 3, 6, 12, or 25 frames/second (for PAL)

Audio:

Enable / Disable for the audio record for each camera channel, when there are no audio input and should make this option OFF, in

order to save the hard disk space;

Live Mode:

Press **ENTER** to choose the option enable or disable;

Enable: The camera allowed to live view

Disable: The camera not allowed to live view.

Remark: there are how many cameras set as enable, then on live view, it will show how many cameras.

e.g.: Only CH1 set as enable, then on live view, CH1 will show on screen on entire screen.

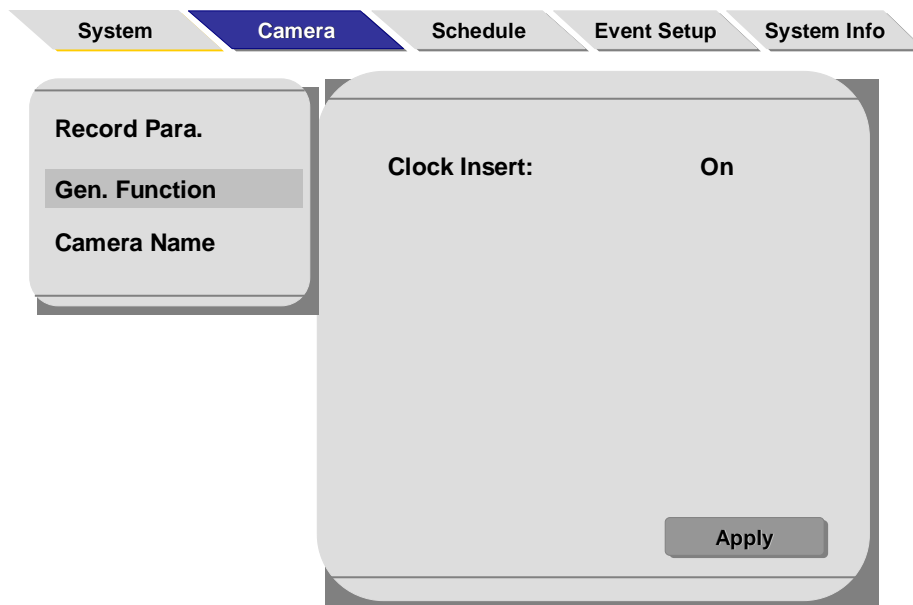
**Time Insert:**

Press **ENTER** to switch between "ON" and "OFF" to embed time/date in the video when recording.

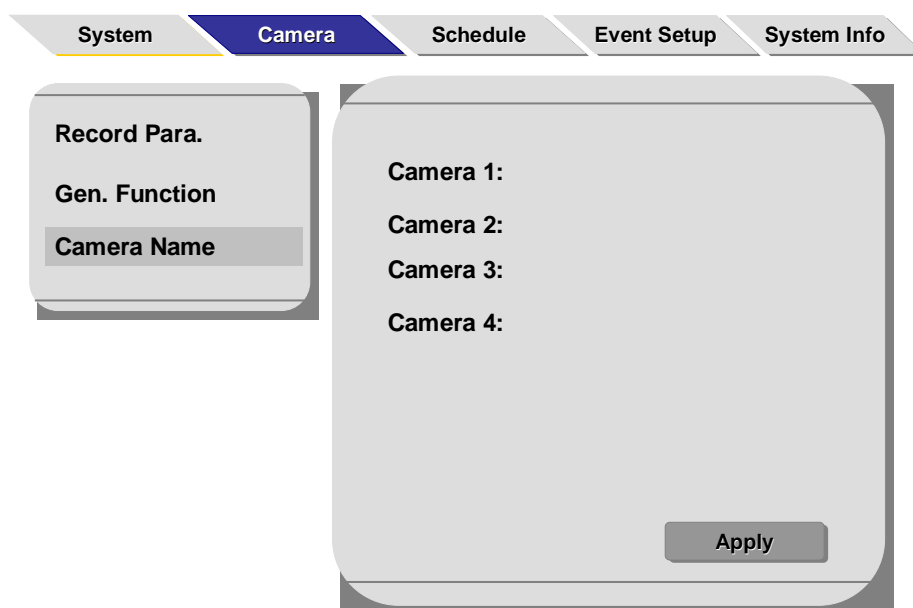

Camera Name: Type in the title for each camera to appear on the video display. The camera label is embedded on the video (8 letters max)

Scroll to **APPLY** and press **ENTER** to save the new settings.

V-3 Schedule:

- ◆ Press **ENTER** to activate (ON) recording schedule.
- ◆ Press the **ARROW** keys to change between any fields in the menu.

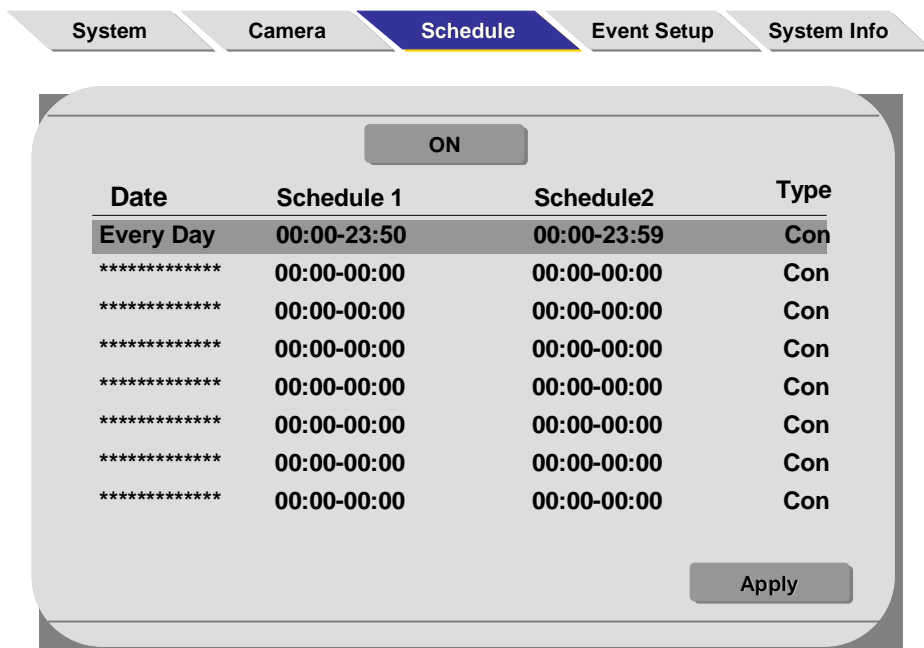

- Date:** Press **ENTER** to change the period of time to control the recording schedule
- ◆ **Single Day:** Choose the name of a day to create a recording schedule
 - ◆ **Every Day:** Choose "Every" to apply a schedule to every day of the week
 - ◆ **Weekday:** Schedule will only apply Weekdays (weekday is from Monday to Friday)
 - ◆ *******:** Choosing the asterisks will suspend the highlighted schedule
- Type:** Press **ENTER** to change the type of the recording mode:
- ◆ **Con:** Continuous recording
 - ◆ **MBR:** Motion Based Recording
 - ◆ **SEN:** Sensor Trigger Based Recording

Schedule 1 / 2:

- ◆ Press the **RIGHT ARROW** key to enter values using the **NUMERIC** keypad into any time field;
- ◆ Schedule 1 is the first of two possible **ON/OFF** cycles that apply to any day in the period chosen under Date.
- ◆ Schedule 2 is the second cycle for any day in the period. There is no need to overlap times of Schedule 1 and Schedule 2.
- ◆ Ending at 23:59 of one day and beginning with 00:00 of the next day will provide continuous recording without interruption (factory default setting)

Remark: When same date/time, only on the condition that the schedule set as "con" type, priority record can be available. Then Sensor can trigger full frames recording. Full recording is not 30 or 25 but depends on the settings for F.R on camera menu.

Scroll to **APPLY** and press **ENTER** to save the new settings.

V-4 Event Setup

Choose the Event Setup tab and press enter to access the following menu. There are 3 option under this item: Sensor, Motion Detect and Others Set:

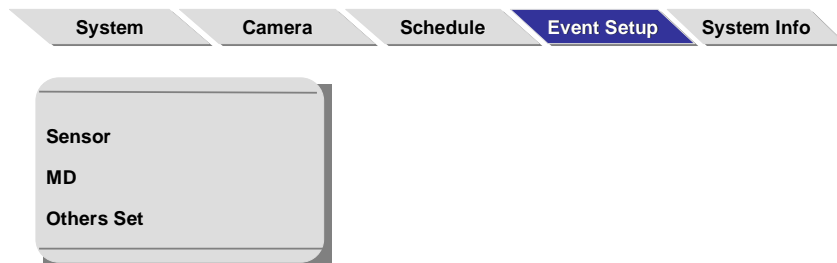

V-4-1 Sensor Menu:

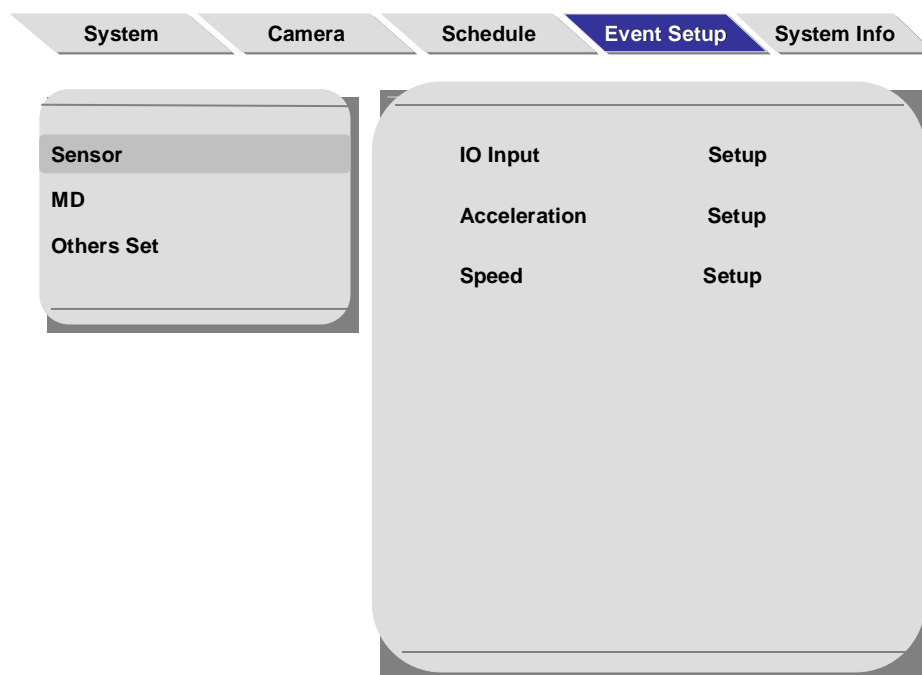

V-4-1-1 I/O Input setup menu: (press setup to enter)

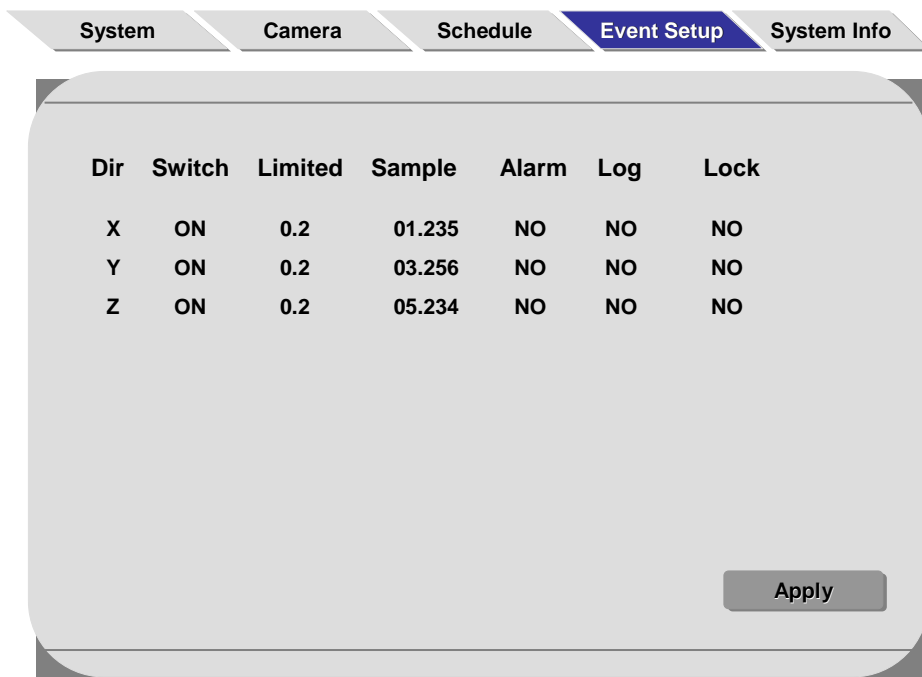

This menu is used for inertia sensor, It has three directions: **X / Y / Z**

X / Y / Z value only used when the MDR connected with inertia sensor, which can detect the vehicle acceleration force or G force. For example, application as when the vehicle being driving too fast when cross the road bump, then the "Z" value would over limit, and to make the sensor trigger.

Switch: Set as ON, the sample value (current value of inertia sensor) will record on the video when recording.

Limited: This is the limited value for inertia sensor, when the currently value is over the limited, and alarm set on, it will trigger alarm signal to remind driver.
Range: 0.2, 0.4, 0.8, 1.0, 1.2, 1.4, 1.6, 1.8, 2.0

Sample: This is the current value, it changes when the inertia sensor moving.

Alarm: Press **ENTER** to select NO/YES, YES means when some directory' s sample value over it's limited, alarm LED will flashing, until re-login the system with account ,the flashing will disappear, also, if the security set as NO, I.E no need enter password to re-login, just pressing ENTER can disappear the flashing.

LOG: Press **ENTER** to select NO/YES to enable or disable the input sensor to put as event log file;



e.g.: If set as OFF, using **Event** option ,even limited value is over, there is no event file on this menu.

LOCK: To enable the event does not erase during the over-write process of hard disk;
Remark: *If switch/alarm/log/lock all set as YES, the sample value (current value of inertia sensor) will recorded on the video when recording. and when over, it will trigger alarm signal and event log, it will also trigger alarm recording and event recording , besides, the EVENT LOG can't be deleted even HDD-formatted or overwrite.*

V-4-1-3 Speed setup menu:

System	Camera	Schedule	Event Setup	System Info	
Speed Setup					
Source:	GPS/Vehicle				
Speed Unit:	KM/H				
Check:	000	000	Check		
Speeding	Switch	Speed	Alarm	Log	Lock
Low	OFF	082	YES	YES	YES
High	ON	120	YES	YES	YES
<input type="button" value="Apply"/>					

Source: MDR is capable of capturing vehicle speed via GPS antenna or Vehicle--speedometer.

- Browse between the settings of GPS or speedometer from the list.
- Please note that the GPS antenna should be connected to MDR to receive satellite signals for speed.
- For more information on capturing speed from speedometer please contact local distributor for more technical support;

SPD Check: Speed check is used to calibrate the offset speed when connected to the speedometer. That's to say, the check only available when speed source is vehicle.

- Input the first area with the vehicle speed, for example at 80 (in KM/H)
- Start the vehicle and the second area will show the data from speedometer (in HZ)
- When the vehicle reach to 80 KM/H (shown in vehicle meter or dash board), and keep this speed at 30 seconds, then press the "Check" to make the system calibrate the second area (HZ) set as first area data (80);

Low Speed Limit: If the vehicle exceeds the low speed limit, MDR will trigger the alarm signal (when the following option ALARM set as YES) until the driver slows down the speed

High Speed Limit: If the vehicle exceeds the high speed limit, MDR will trigger the alarm signal (when the following option ALARM set as YES) until the Admin password is entered to acknowledge the alarm.

Alarm: Press **ENTER** to select NO/YES, yes means when some directory' s sample value over it's limited, alarm LED will flashing, until re-login the system with account ,the flashing will disappear, also, if the security set as no, I.E no need enter password to re-login, just pressing ENTER can disappear the flashing.

LOG: Press **ENTER** to select NO/YES to enable or disable the input sensor to put as event log file;

e.g.: If set as OFF, using  **Event** option ,even limited value is over, there is no event file on this menu.

LOCK: To enable the event does not erase during the over-write process of hard disk;
Remark. *If switch/alarm/log/lock all set as YES, When vehicle speed over the limited speed,*

it will trigger alarm signal and event log, it will also trigger alarm recording and event recording .besides, the log can't be deleted even HDD-formatted or overwrite.

Scroll to **APPLY** and press **ENTER** to save the new settings.

V-4-2 Motion Detect Menu:

System	Camera	Schedule	Event Setup	System Info		
	Camera	Switch	Area	Alarm	Log	Lock
	1	Off	Setup	No	No	No
	2	Off	Setup	No	No	No
	3	Off	Setup	No	No	No
	4	Off	Setup	No	No	No
Apply						

Switch: For each camera, enable / disable by ON/OFF in “MD” section

Area Set: Select the area the allow to have motion detection block:

- Totally with 192 blocks on screen;
- Press **ENTER** to make the block in Green color as active block and select the block with direction keys;
- Re-press “**ENTER**” to trigger off to make as transparent;
- Press “Setup” to make full screen selection;
- Re-press “Setup” to trigger off the full screen selection;
- When the motion detected in the block, it will shown as red color block;

Alarm: When in schedule, the type is set as MBR, and the sensitivity value is set as proper (1-16,1 mean the high sensitivity), if in the set area moving occurs, it will trigger alarm signal (alarm LED flashing)and recording

Remark: *How to set the sensitivity: stopping all recording(no red square showing), on live view when login ,press ADJUST key to set the sensitivity*

LOG: Enable the motion detection in the log record file;

LOCK: To enable the event does not erase during the over-write process of hard disk;

Scroll to **APPLY** and press **ENTER** to save the new settings.

V-4-3 Others set menu:

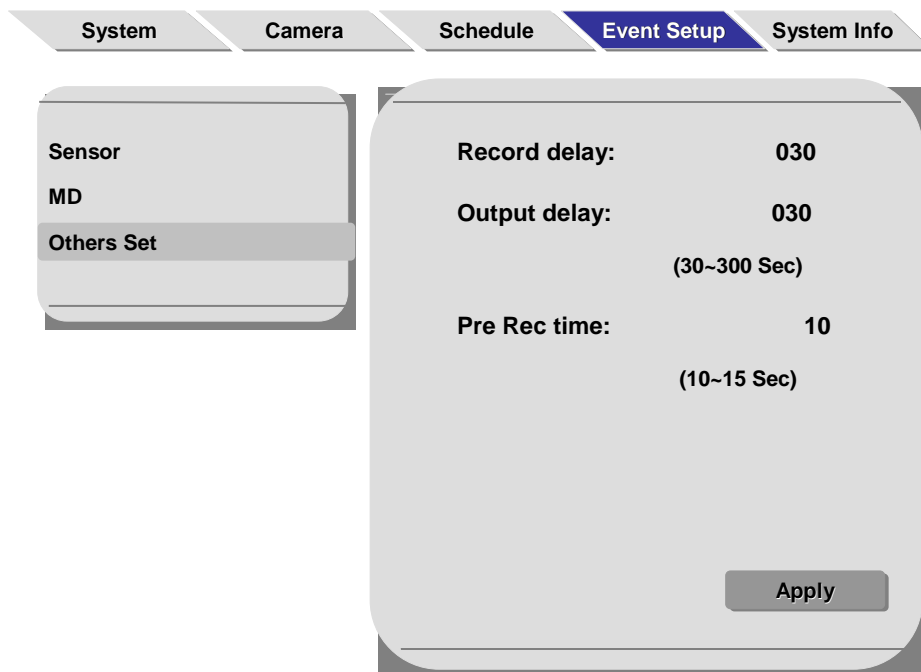

- Recording delay:** Use the Numeric key pad or ARROW down to the second settings to define the time duration of full-rate recording (alarm recording) after the trigger is over.
- Output delay:** To set the time duration of alarm LED flashing after the trigger is over.
- Pre Rec Time:** To set the pre recording time before trigger is over

V-5 System Information:

Press **ENTER** to access the System Information menu.

This menu displays DVR information that may be required for technical support. In addition, information regarding the installed hard disk also displayed. In this menu, user can clear the log information of the DVR.

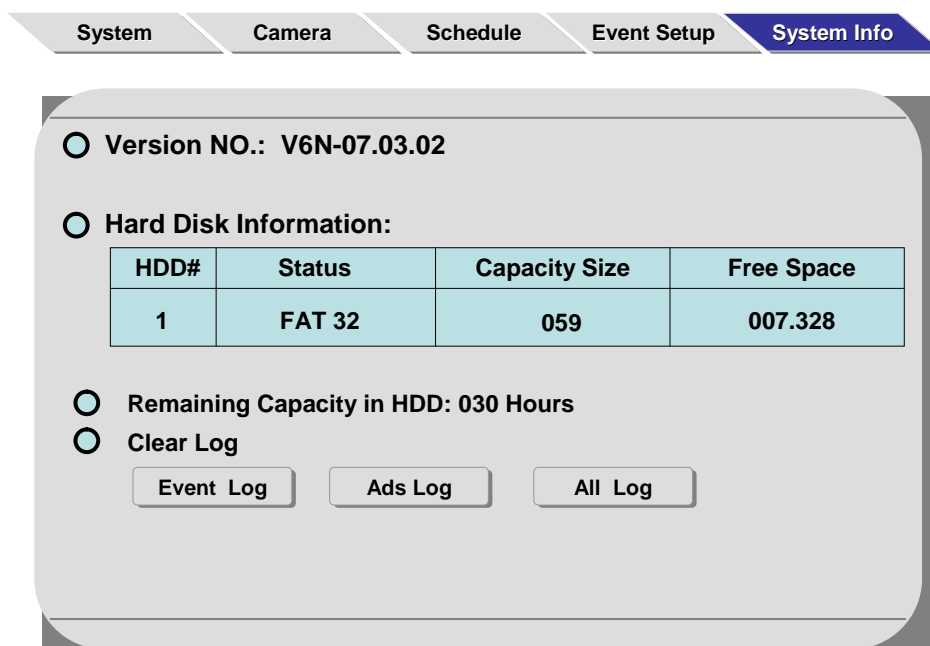

- ◆ **Version No:** This is the device firmware version number, it might need to used when there are any technical question and user require to refer this information to technical support staff;

- ◆ **Hard Disk Information:**

This will show that the built-in Hard disk format and size. If user find the hard disk status as FAT or size as "000". Please re-format hard disk to check the hard disk status again.

① **Notice :** The Hard disk consumption calculator available by distributor or direct dealer;

V-6 System Information (con't):

System	Camera	Schedule	Event Setup	System Info								
<input type="radio"/> Version NO.: V6N-07.03.02												
<input type="radio"/> Hard Disk Information: <table border="1"> <thead> <tr> <th>HDD#</th> <th>Status</th> <th>Capacity Size</th> <th>Free Space</th> </tr> </thead> <tbody> <tr> <td>1</td> <td>FAT 32</td> <td>059</td> <td>007.328</td> </tr> </tbody> </table>					HDD#	Status	Capacity Size	Free Space	1	FAT 32	059	007.328
HDD#	Status	Capacity Size	Free Space									
1	FAT 32	059	007.328									
<input type="radio"/> Remaining Capacity in HDD: 030 Hours												
<input type="radio"/> Clear Log												
<input type="button" value="Event Log"/> <input type="button" value="Ads Log"/> <input type="button" value="All Log"/>												

- ◆ **Clear [Event Log]/ [Ads Log]:**

select this option and press [Enter], the DVR will prompt a confirmation message. Select [YES] and press [Enter]. This will clear the log file from the unit. Select [NO] to cancel to clear the log file.

- ◆ **[All Logs]:** select this option to clear both [Event Log] and [Advert Log] file simultaneously.

WARNING!! The log entries in the **EVENT** are also a part of the log file. Deleting the Event log file will also delete the entries in the **EVENT**.

VI. Procedure for upgrading System Firmware

VI-1 Upgrading firmware:

There are 2 methods to upgrade the firmware in the MDR:

VI-1-1 Hard disk upgrade Instructions:

- Connect and Enable the USB
- Copy the romfs.dvr file by pressing ctrl + c or going to Edit -> Copy

-
- c) Open the ADS folder on the MDR HDD
 - d) Paste the file in the “ADS” folder by pressing ctrl + v or going to Edit -> Paste
 - e) Restart the unit. The system will start to upgrade automatically and the screen display with “Upgrading in progress, please wait...”



Please wait while the system is updated

- f) During the upgrade [POW] and [ALM] LED will start to flash
- g) Once completed the upgrade file will be deleted automatically



System Upgrade Successful, system restart

VI-1-2 Compact Flash upgrade Instructions:

A Compact Flash (CF) card can also be used to update the firmware in the unit. Please follow the instructions to update the flash using the CF card:

- a) Insert a CF card into the CF slot of your Windows PC (Drive letter appears)
- b) Using Windows Explorer, format the CF card as FAT32 format. All the data will be permanently erased from the CF card.

- c) Copy the new firmware (romfs.dvr file) on the CF card
- d) Remove the CF from the PC and insert it into the slot on your MDR while power off.
- e) Upon turning the power on, the unit will automatically start to update the new firmware from the CF card. During the upgrade [POW] and [ALM] LED will start to flash
- f) Remove the CF card from the MDR unit once completed.

WARNING: *The upgrade procedure requires no power interruption. The CF card slot on the unit is a necessary opening on the unit. Please ensure that no liquid is spilled on the slot. In addition, install the system where dust and dirt are also not likely to contaminate the opening.*

VI-2 Customize Background upgrade Instructions:

Steps for updating the background:

1. Name the logo as background, the format for the picture is .jpg, the size should be less than 40KB, and the Resolution is 720*480.
 2. Please place the file in the HDD via USB, the USB operation please do as below:
 - a. **Connect** MDR to PC via USB cable
 - b. Go into the **System Setup** menu, please select **USB operation**, choose **Device mode (connect to PC)**, then **apply**.
- Note:** when **apply**, don't exit, just wait to find HDD in your PC. if you can't find the HDD a moment later, please re-connect it to PC.
- c. Put the **background** file into the **root directory** of the HDD.
 - d. Finally, please press **EXIT**, MDR will restart, then you can see the logo is just the updated logo.

Remark: When changing the HDD, please update the logo again, because the logo is just in HDD, not the main board by this way.

VII. Compact Flash Card management



Insert the CF Card into CF Slot, the CF Card mark **CF Card** will show on the screen, press [CF] button on the handheld IR. A screen will pop up with the following options:

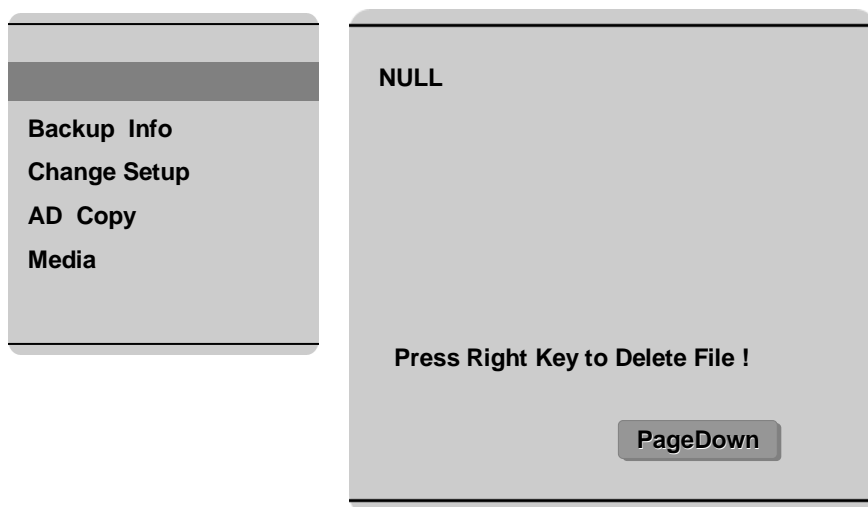

VII-1 Recoding File:

If there are any video recorded files on the CF card this option allow to play back the recordings. Select the

“Operate CF Card” and press [Enter], the screen will show as below:

- ◆ Please allow the system to show the record files on the CF card. Select the file and press [Enter] key to playback.
- ◆ If you want to delete the record file, press the right direction key [▶].
- ◆ If CF does not contain any record files then “No Record” message will be displayed.

VII-2 Backup setup:

This option enables the user to copy the setup of MDR to CF Card. Use this option if the same settings are required to be applied on more than one MDR units. Once the backup finishes, take the CF card to second MDR unit and follow the Change Setup Option.

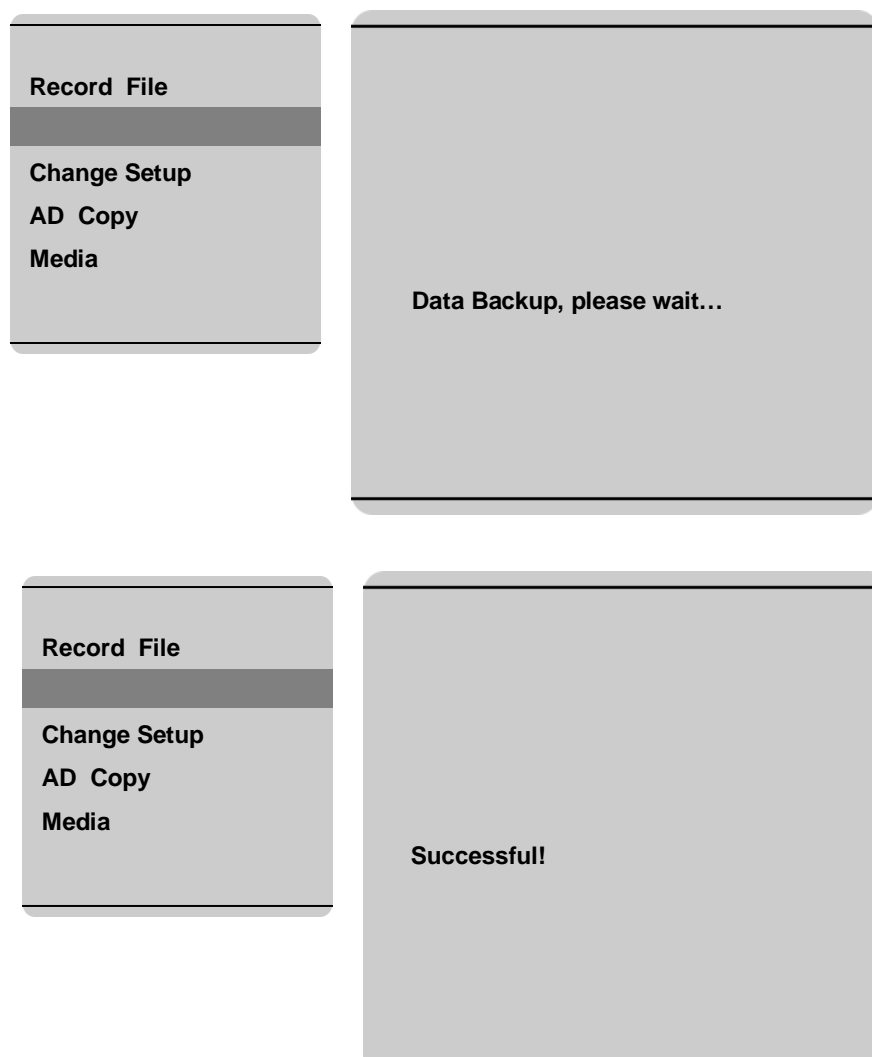

VII-3 Change Setup:

This option allows changing the settings based on the setting file stored on the CF card. Select this option and press [Enter] button. A message will pop up “Changing setup...” while the setup process is changed. Once completed successfully the unit will display a confirmation message. The unit will restart for the new changes to take affect.

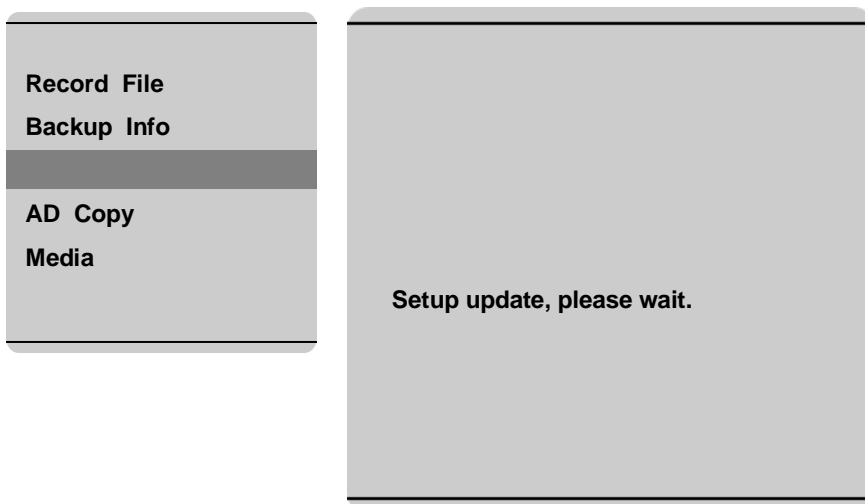

VII-4 AD Copy:

Advertisement option displays the advertisement files on the CF card. Select the desired file to upload and press [CF] button of the handheld control, the unit will copy the advertisement file to DVR. Status indicator will show the percentage of the files being copied. Once completed successfully the unit will display a confirmation message.



NOTE: When copying the advertising contents to the CF card using Windows PC, create a folder called “Ads” on the CF card. All the advertising media contents should be copied to Ads folder for uploading the advertisement on MDR.

VII-5 Media:

Movie & Music option displays the movie and music files on the CF card. Select the desired file to upload and press [CF] button of the handheld control, the unit will copy the file to DVR. Once completed successfully the unit will display a confirmation message.

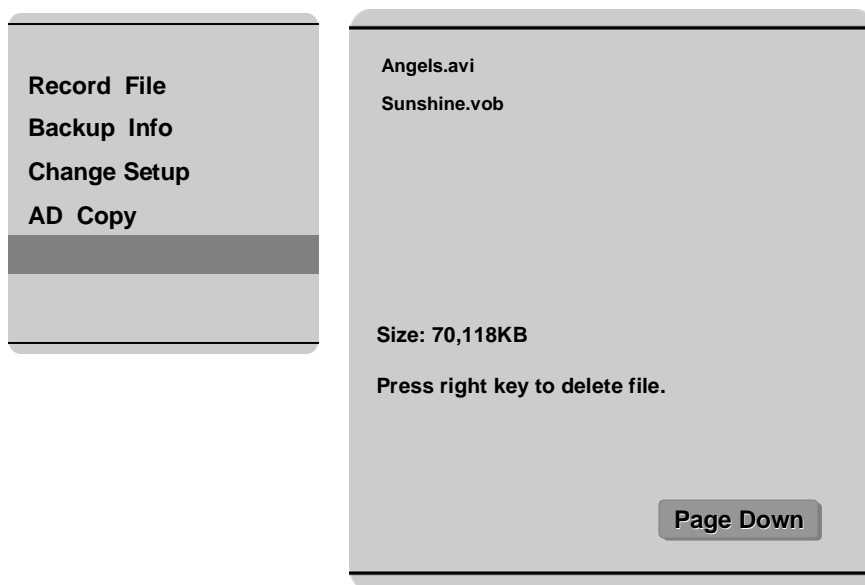

VIII. Hard Disk File Structure

Hard Disk file structure: Using the USB to connect the DVR to PC the file structure of the unit looks like below:



Folder Name	Contents/ Description	Remark
Ads	List of the advertisement file	Supported format: MPEG4, MPEG2, MPEG1 File extension : VOB, MPG, AVI, DAT
Ads_log	Log file for tracking all the advertisement playback history by DVR (this contains playback time, interval, number)	Use log viewer application to open this file (provide by)
Alarm	Alarm recording	Requires client software to playback video from PC. Or downloading via USB All the record file are watermarked for authenticity
Record	Normal recording	Requires client software to playback video from PC. Or downloading via USB All the record file are watermarked for authenticity
Movie	List of the movie file	Supported format: MPEG4, MPEG2, MPEG1 File extension : VOB, MPG, AVI, DAT
Music	List of the music file	Supported format: WAV MP3 WMA
Time	System file	DO NOT DELETE THE FILE. THIS IS A NECESSARY FILE NEEDED BY THE SYSTEM TO FUNCTION PROPERLY

IX. GPS Operation (Optional)

This feature is only available with the system connected with GPS antenna.

1. To enable the feature make sure to connect the GPS antenna to the GPS connection port located at the back of docking station.
2. Once connected properly and placed outside the vehicle facing towards the sky, you will find the GPS icon display on the surveillance screen as shown:



3. The GPS data will appear on the screen as:
 - N for longitude
 - W for latitude
 - Vehicle Speed

4. The values of GPS are embedded on the video and could be retrieved by using the video playback function.

